

*Feel Yourself a Student!*

Dear friends, I would like to give to you an interesting and reliable antenna theory. Hours searching in the web gave me lots theoretical information about antennas. Really, at first I did not know what information to chose for ANTENTOP. Finally, I stopped on lectures "Modern Antennas in Wireless Telecommunications" written by Prof. Natalia K. Nikolova from McMaster University, Hamilton, Canada.

*You ask me: Why?*

Well, I have read many textbooks on Antennas, both, as in Russian as in English. So, I have the possibility to compare different textbook, and I think, that the lectures give knowledge in antenna field in great way. Here first lecture "Introduction into Antenna Study" is here. Next issues of ANTENTOP will contain some other lectures.

***So, feel yourself a student! Go to Antenna Studies!***

I.G.

***My Friends, the Intro was given at ANTENTOP- 01- 2003 to Antennas Lectures.***

***Now I know, that the Lecture is one of popular topics of ANTENTOP- 01- 2003. The Lecture was downloaded 1000 times to September, 12! Not bad!***

***Now I want to present you one more very interesting Lecture - it is a Lecture about practical constructing of all shapes dipoles. I believe, you cannot find such info anywhere for free! Very interesting and very useful info for every ham, for every radio- engineer.***

***So, feel yourself a student! Go to Antenna Studies!***

I.G.

*McMaster University Hall*

***Prof. Natalia K. Nikolova***



***LECTURE 10: Other Practical Dipole/Monopole Geometries.  
Matching Techniques for Dipole/Monopole Feeds.***

*(The folded dipole antenna. Conical skirt monopoles. Sleeve antennas. Turnstile antenna. Impedance matching techniques. Dipoles with traps.)*

by Prof. Natalia K. Nikolova

All lectures are available at: [http://www.ece.mcmaster.ca/faculty/georgieva/antenna\\_dload/](http://www.ece.mcmaster.ca/faculty/georgieva/antenna_dload/)

## LECTURE 10: Other Practical Dipole/Monopole Geometries.

### Matching Techniques for Dipole/Monopole Feeds.

*(The folded dipole antenna. Conical skirt monopoles. Sleeve antennas. Turnstile antenna. Impedance matching techniques. Dipoles with traps.)*

#### 1. Folded dipoles

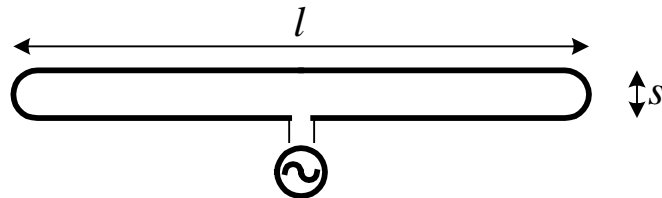

The folded dipole is a very popular antenna for reception of TV broadcast signals. It has essentially the same pattern as the dipole of the same length  $l$  but it provides four times greater input impedance when  $l \approx \lambda/2$ . The length of a single-wire dipole is usually  $\lambda/4 \leq l \leq \lambda$  for best directivity with no side lobes. Most often,  $l \approx \lambda/2$ . The input resistance then is  $R_{in} \approx 73 \ \Omega$ . Wire antennas are not fit to coaxial feed lines because of the different field structure. However, they are ideally suited for twin-lead (two-wire) feed lines. These lines (two parallel thin wire lines separated by a distance of about 8-10 mm) have  $Z_c \approx 300 \ \Omega$ . Therefore, an input antenna impedance of  $(4 \times 73) \ \Omega$  is perfect for matching to 2-wire feed lines. The separation distance between the two wires of the folded dipole should not exceed  $0.05\lambda$ .

The folded dipole can be analyzed by decomposing its current into two modes: the transmission-line mode and the antenna mode. This analysis, albeit approximate<sup>1</sup>, illustrates the four-fold impedance transformation.

---

<sup>1</sup> G.A. Thiele, E.P. Ekelman, Jr., L.W. Henderson, "On the accuracy of the transmission line model for the folded dipole," *IEEE Trans. on Antennas and Propagation*, vol. AP-28, No. 5, pp. 700-703, Sept. 1980.

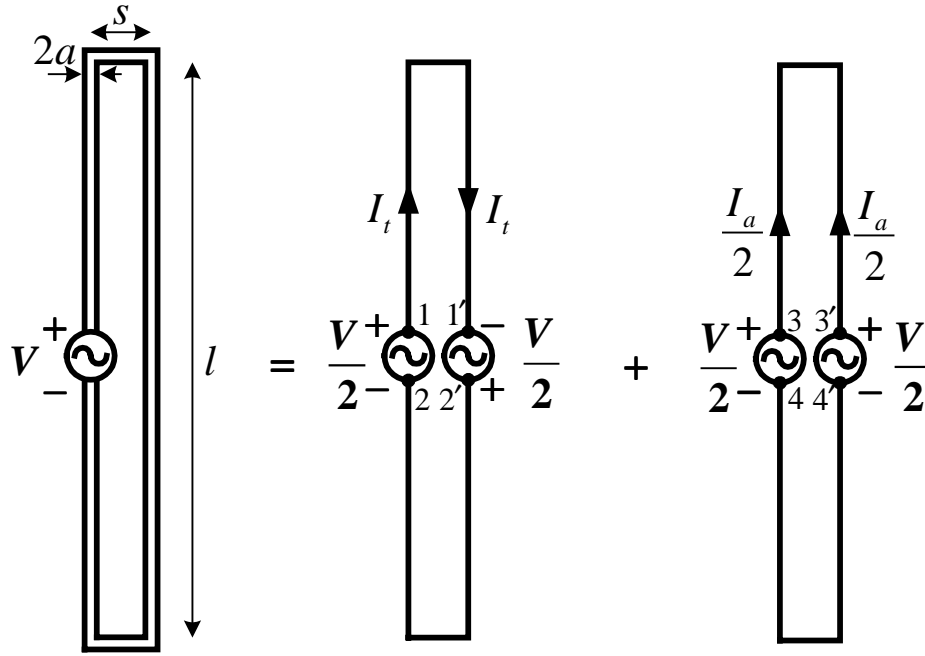

Folded dipole

(a) Transmission-line mode

(b) Antenna mode

The input impedance at the terminals 1-1' and 2-2' can be determined as the input impedance of a shorted transmission line of length  $l/2$ :

$$Z_t = \left[ Z_0 \left( \frac{Z_L + jZ_0 \tan(\beta l/2)}{Z_0 + jZ_L \tan(\beta l/2)} \right) \right]_{Z_L=0} \quad (10.1)$$

$$\Rightarrow Z_t = jZ_0 \tan\left(\frac{\beta l}{2}\right) \quad (10.2)$$

Here,  $Z_0$  is the characteristic impedance of a 2-wire transmission line:

$$Z_0 = \frac{\eta}{\pi} \operatorname{arccosh}\left(\frac{s}{2a}\right) = \frac{\eta}{\pi} \ln \left[ \frac{s/2 + \sqrt{(s/2)^2 - a^2}}{a} \right] \quad (10.3)$$

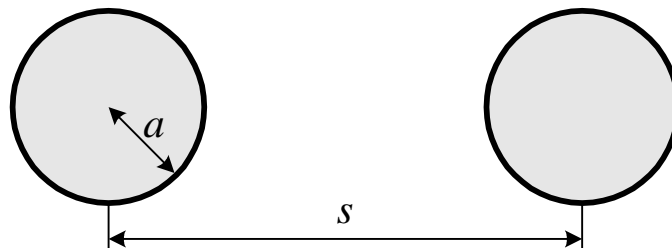

Usually, the folded dipole has a length of  $l \approx \lambda/2$ . Then,

$$Z_t(\lambda/2) = jZ_0 \tan(\pi/2) \rightarrow \infty \quad (10.4)$$

If  $l \neq \lambda/2$ , the more general expression (10.2) should be used. The current in the transmission-line mode is:

$$I_t = \frac{V}{2Z_t} \quad (10.5)$$

Let us consider now the antenna mode. The generators' terminals 3–3' (and 4–4') are with identical potentials. Therefore, they can be connected without loss of generality. The following assumption is made: an equivalent dipole of effective radius

$$a_e = \sqrt{as} \quad (10.6)$$

is radiating excited by  $V/2$  voltage. Since usually  $a \ll \lambda$  and  $s \ll \lambda$ , the input impedance of the equivalent dipole  $Z_a$  is assumed equal to the input impedance of an infinitesimally thin dipole of the respective length  $l$ . If  $l = \lambda/2$ , then  $Z_a = 73 \Omega$ . The current in the antenna mode is:

$$I_a = \frac{V}{2Z_a} \quad (10.7)$$

The current at each leg of the equivalent dipole is obviously

$$\frac{I_a}{2} = \frac{V}{4Z_a} \quad (10.8)$$

The total current of a folded dipole is obtained by combining both modes. At the input

$$I_{in} = I_t + \frac{I_a}{2} = V \left( \frac{1}{2Z_t} + \frac{1}{4Z_a} \right) \quad (10.9)$$

$$\Rightarrow Z_{in} = \frac{4Z_t Z_a}{2Z_a + Z_t} \quad (10.10)$$

When  $l = \lambda/2$  (half-wavelength folded dipole), then  $Z_t \rightarrow \infty$ , and

$$\Rightarrow Z_{in} = 4Z_a \Big|_{l=\frac{\lambda}{2}} \approx 292 \Omega \quad (10.11)$$

Thus, the half-wavelength folded dipole is very well suited for direct connection to a twin-lead line ( $Z_c \approx 300 \Omega$ ). It is often made in a very simple way: a suitable portion (the end part of the twin-lead cable of

length  $l = \lambda/2$ ) is separated into two single wire leads, which are bent to form the folded dipole.

## 2. Conical (skirt) monopoles and discones

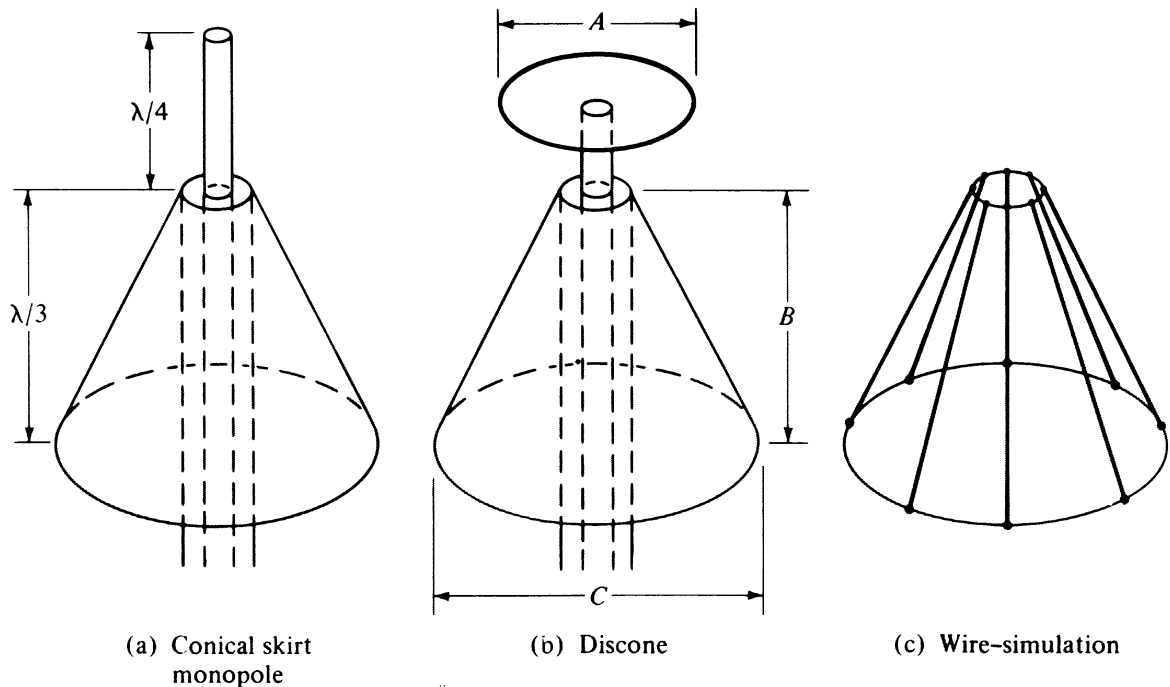

These monopoles have much broader frequency band for their impedance variations (a couple of octaves) than the ordinary quarter-wavelength monopoles. They are a combination of the two basic antennas: the monopole/dipole antenna and the biconical antenna. The discone and conical skirt monopoles find wide application in the VHF (30-300 MHz) and the UHF (300 MHz - 3 GHz) spectrum for FM broadcast, television and mobile communications.

There are numerous variations of the dipole/monopole/cone geometries, which aim at broader bandwidth rather than shaping the radiation pattern. All these antennas provide omnidirectional radiation.

The discone (disk-cone) is the most broadband among these types of antennas. This antenna was first designed by Kandoian<sup>2</sup> in 1945. The performance of the discone in frequency is similar to that of a high-pass filter. Below certain effective cutoff frequency, it has a considerable reactance and produces severe standing waves in the feed line. This

<sup>2</sup> A.G. Kandoian, "Three new antenna types and their application," *Proc. IRE*, vol. 34, pp. 70W-75W, Feb. 1946.

happens approximately at wavelength such that the slant height of the cone is  $\approx \lambda/4$ .

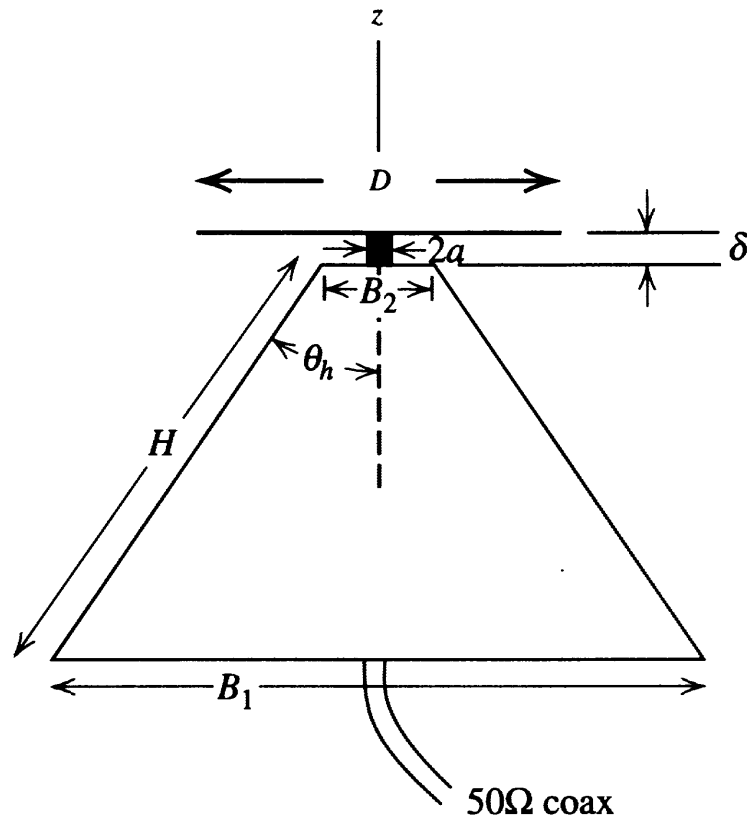

Typical dimensions of a discone antenna at central frequency are:  $D \approx 0.4\lambda$ ,  $B_1 \approx 0.6\lambda$ ,  $H = 0.7\lambda$ ,  $45^\circ \leq 2\theta_h \leq 75^\circ$  and  $\delta \ll \lambda$ . The typical input impedance is designed to be  $50 \Omega$ . Optimum design formulas are given by Nail<sup>3</sup>:  $B_2 \approx \lambda_u/75$  at the highest operating frequency,  $\delta \approx (0.3 \div 0.5)B_2$ , and  $D \approx 0.7B_1$ .

<sup>3</sup> J.J. Nail, "Designing discone antennas," *Electronics*, vol. 26, pp. 167-169, Aug. 1953.

Measured patterns for a disccone:  $H = 21.3$  cm,  $B = 19.3$  cm,  $\theta_h = 25^\circ$ :

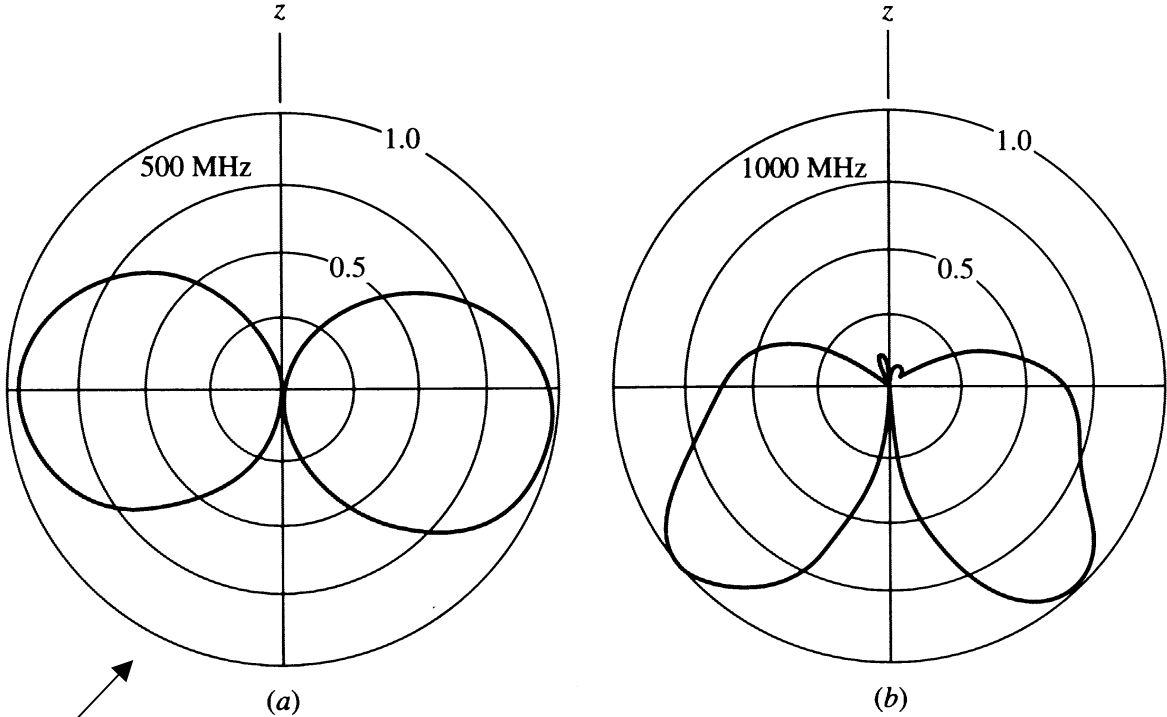

Similar to a short dipole

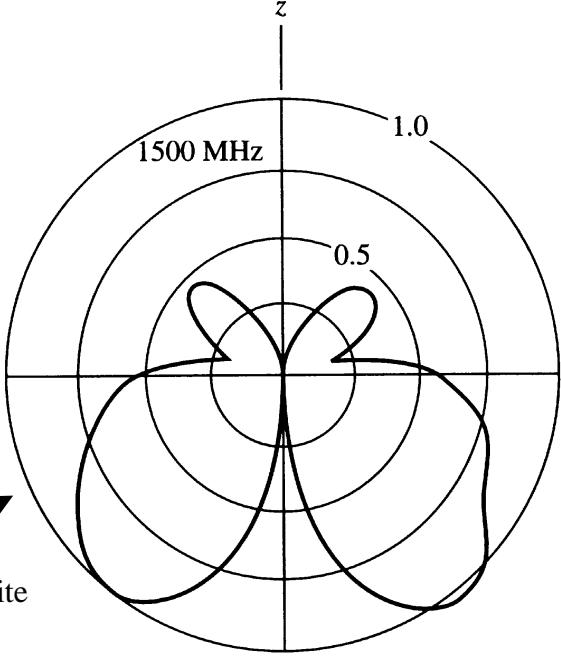

Similar to an infinite conical monopole

### 3. Sleeve (coaxial) dipoles and monopoles

The impedance of dipole/monopole antennas is very frequency sensitive. The addition of a sleeve to a dipole or a monopole can increase the bandwidth up to more than an octave.

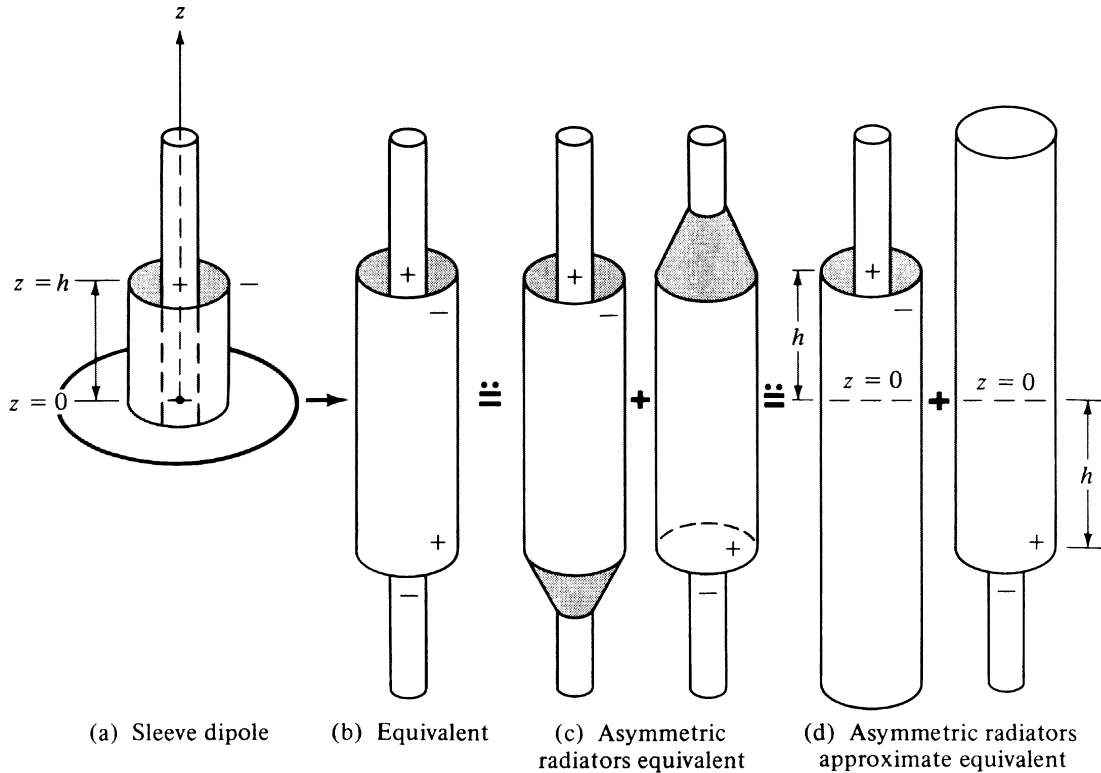

Sleeve dipole and its equivalents. (SOURCE: W. L. Weeks, *Antenna Engineering*, McGraw-Hill, New York, 1968)

This type of antenna closely resembles an asymmetric dipole, and can be analyzed using the approximation in (d). The outer shield of the coaxial line is connected to the ground plane, but it also extends above it a distance  $h$ , in order to provide mechanical strength, impedance tuning and impedance broadband characteristics. The equivalent in (d) consists of two dipoles, which are asymmetrically driven at  $z' = +h$  or  $z' - h$ . When analyzing the field of the two asymmetrically driven dipoles, one can ignore the change in diameter occurring at the feed point.

The input impedance of an asymmetric dipole can be related to its self-impedance approximately as:

$$Z_{as} = \frac{Z_m}{\sin^2 \left[ \beta \left( \frac{l}{2} - h \right) \right]} \quad (10.12)$$

where  $h$  is the off-center displacement. The relation (10.12) was already derived when the centered-feed impedance of a dipole of arbitrary length was analyzed in Lecture 7. A symmetrically driven dipole would have an input impedance of:

$$Z_s = \frac{Z_m}{\sin^2 \left( \beta \frac{l}{2} \right)} \quad (10.13)$$

For a half-wavelength dipole ( $l = \lambda/2$ ), it is easy to show that the relation between the input impedance of the asymmetric dipole  $Z_{as}$  and the center-fed symmetric dipole  $Z_s$  is:

$$Z_{as} \approx \frac{Z_s}{\cos^2(\beta h)} \quad (10.14)$$

The general expression is:

$$Z_{as}(h) \approx Z_s \frac{\sin^2 \left( \beta \frac{l}{2} \right)}{\sin^2 \left[ \beta \left( \frac{l}{2} - h \right) \right]} \quad (10.15)$$

From (10.15) or from (10.12) it is obvious that one can control the input impedance by shortening or extending the sleeve along the stub.

The equivalent antenna structure in (d) actually consists of two asymmetrically driven dipoles. The total input current is:

$$I_{in} = I_{as}(z' = +h) + I_{as}(z' = -h) \quad (10.16)$$

The input admittance is:

$$Y_{in} = \frac{I_{in}}{V_{in}} = \frac{I_{as}(z' = +h) + I_{as}(z' = -h)}{V_{in}} = \frac{I_{as}(z = h)}{V_{in}} \left[ 1 + \frac{I_{as}(z = -h)}{I_{as}(z = +h)} \right] \quad (10.17)$$

$$\Rightarrow Y_{in} = Y_{as} \left[ 1 + \frac{I_{as}(z' = -h)}{I_{as}(z' = +h)} \right] \quad (10.18)$$

Here,  $Y_{as} = 1/Z_{as}$  can be calculated from (10.15). The assumption for a sinusoidal current distribution dictates that the currents in (10.18) should be calculated from the formula:

$$I(z') = I_m \sin \left[ \beta \left( \frac{l}{2} - |z'| \right) \right] \quad (10.19)$$

Since the two dipoles in (d) are geometrically identical, it follows from (10.18) that:

$$Y_{in} \approx 2Y_{as} \quad (10.20)$$

The first sleeve monopole resonance will occur at a length of approximately  $l \approx \lambda/4$ . The other important design variable is the monopole-to-sleeve ratio  $\eta = (l-h)/h$ . It has been experimentally established that  $\eta = 2.25$  yields optimum (nearly constant with frequency) radiation patterns over a 4:1 band. The value of  $\eta = (l-h)/h$  has little effect on the radiation pattern if  $l \leq \lambda/2$ , since the current on the outside of the sleeve will have approximately the same phase as that on the top portion of the monopole itself. However, for longer lengths, the ratio  $\eta$  has marked effect on the radiation patterns since the current on the outside of the sleeve will not necessarily be in-phase with that on the top portion of the monopole.

Some practical geometries:

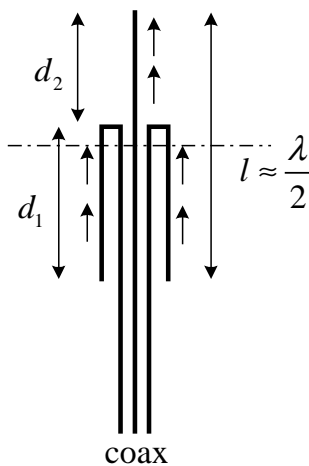

(a) asymmetrically-fed sleeve dipole

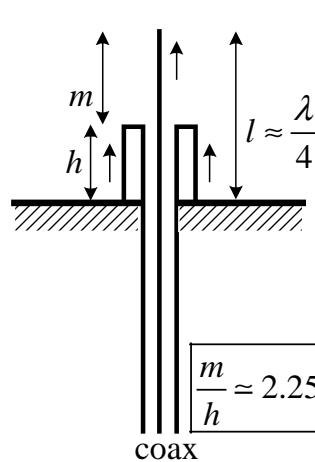

(b) sleeve monopole

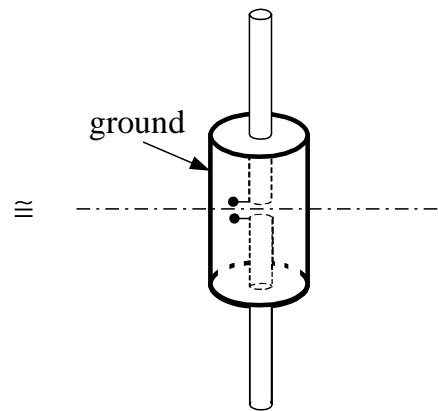

(c) sleeve dipole

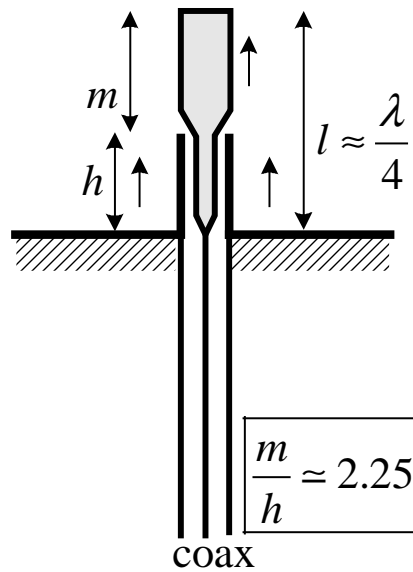

(d) another sleeve monopole

Up to now, it was always assumed that the cross-section of the wire is circular of radius  $a$ , when deriving the expressions for the input impedance. An electrical equivalent radius can be obtained for some uniform wires of non-circular cross-section. This is very helpful when calculating the impedance of dipoles made of non-circular cross-section wires. The equivalent radii for certain wires are given below.

**Table 9.3** CONDUCTOR GEOMETRICAL SHAPES AND THEIR EQUIVALENT CIRCULAR CYLINDER RADII

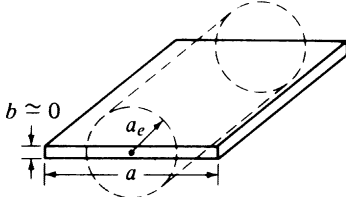
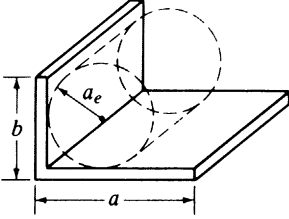
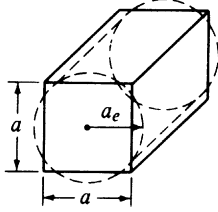
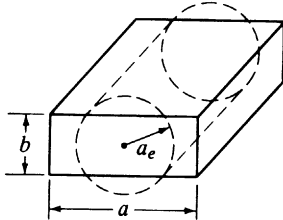
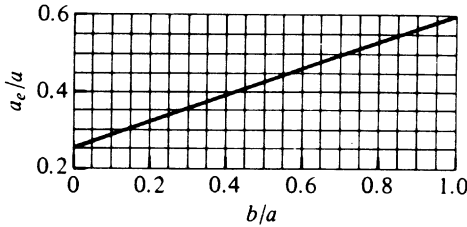
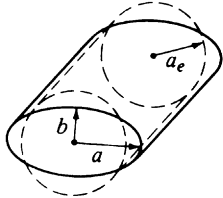
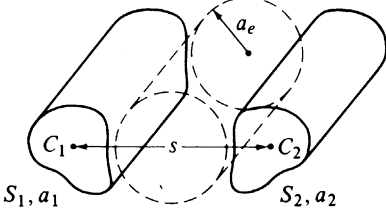
| Geometrical Shape   | Electrical Equivalent Radius   |
|---|--|
|    | $a_e = 0.25a$  |
|    | $a_e \approx 0.2(a + b)$   |
|   | $a_e = 0.59a$  |
|  |    |
|  | $a_e = \frac{1}{2}(a + b)$   |
|  | $\ln a_e \approx \frac{1}{(S_1 + S_2)^2} \times [S_1^2 \ln a_1 + S_2^2 \ln a_2 + 2S_1 S_2 \ln s]$ <p> <math>S_1, S_2 =</math> peripheries of conductors <math>C_1, C_2</math><br/> <math>a_1, a_2 =</math> equivalent radii of conductors <math>C_1, C_2</math> </p> |

#### 4. Turnstile antenna

The turnstile antenna is a combination of two orthogonal in space dipoles fed in phase-quadrature. This antenna is capable of producing circularly polarized field in the direction, which is normal to the dipoles' plane. It produces an isotropic pattern in the dipoles' plane (the  $\theta$ -plane) of linearly (along  $\hat{\theta}$ ) polarized wave. In all other directions, the wave is elliptically polarized.

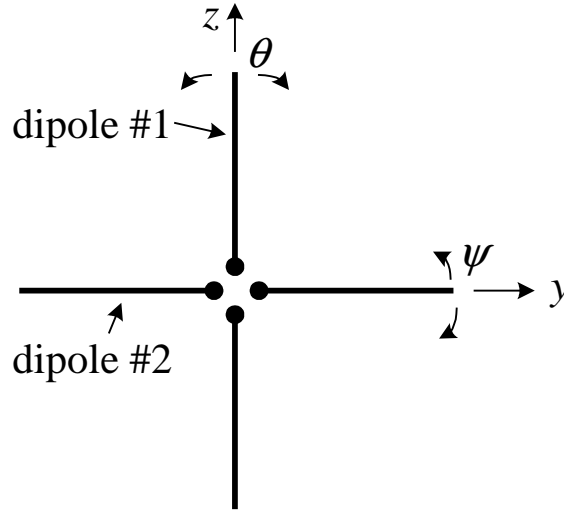

In the  $\varphi = 90^\circ$  - plane (the  $y - z$  plane in which the dipoles lie), the field is a superposition of the fields whose patterns are:

$$\bar{E}_\theta^{(1)}(t) = \sin \theta \cos \omega t \quad (10.21)$$

$$\begin{aligned} \bar{E}_\psi^{(2)}(t) &= \sin \psi \cos(\omega t \pm \pi / 2) = \pm \sin \omega t \cdot \sqrt{1 - \sin^2 \theta \sin^2 \varphi} = \\ &= \pm \cos \theta \cdot \sin \omega t \end{aligned}$$

$$(10.22)$$

In the  $\varphi = 90^\circ$  - plane, the  $\psi$ -component of a vector is actually a  $\theta$ -component. Equations (10.21) and (10.22) define a total field of:

$$\bar{E}_\theta(t, \theta) = \sin \theta \cos \omega t \pm \cos \theta \sin \omega t \quad (10.23)$$

which reduces to

$$\bar{E}_\theta(t, \theta) = \sin(\theta \pm \omega t) \quad (10.24)$$

The rms pattern is circular, although the instantaneous pattern rotates.

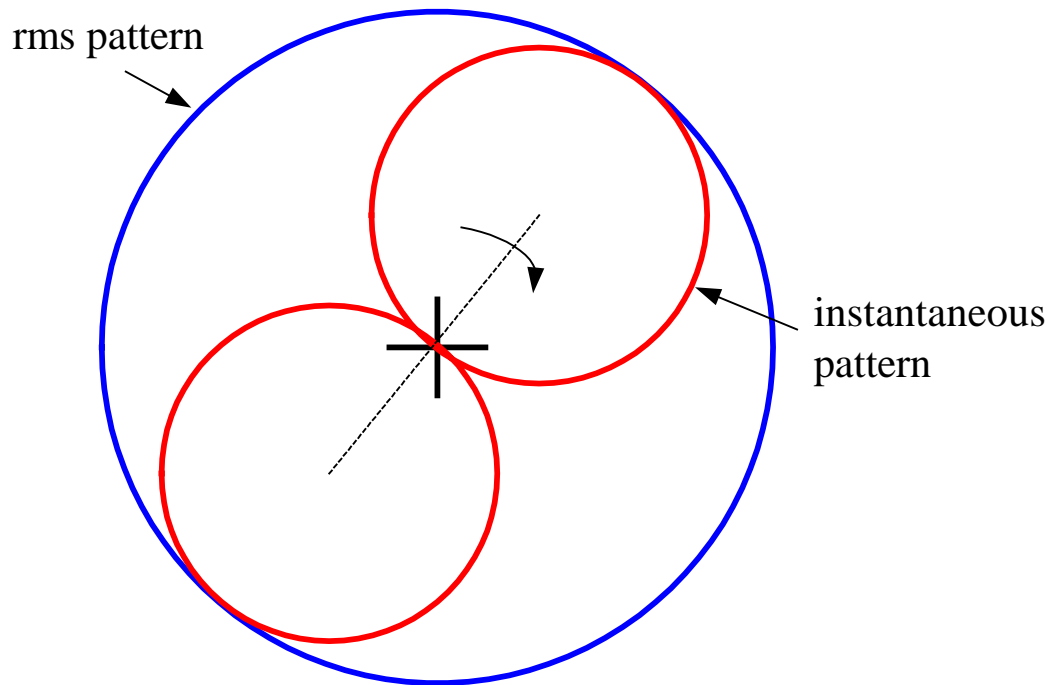

## 5. Matching techniques for wire antennas

There two major issues when constructing the feed circuit: impedance matching and balanced-unbalanced matching.

### 5.1. Impedance matching

$$VSWR = \frac{1+|\Gamma|}{1-|\Gamma|} \quad (10.25)$$

Reflected power in terms of VSWR:

$$|\Gamma|^2 = \left( \frac{VSWR - 1}{VSWR + 1} \right)^2 \quad (10.26)$$

Transmitted power:

$$|T|^2 = 1 - |\Gamma|^2 \quad (10.27)$$

Impedance mismatch is undesirable not only because of the inefficient power transfer. In high-power transmitting systems, high VSWR leads to maxima of the standing wave, which can cause arcing. Sometimes, the frequency of the transmitter can be affected by severe impedance mismatch (“frequency pulling”).

TABLE: VSWR and Transmitted Power

| VSWR | $ \Gamma ^2 \times 100\%$ | $ T ^2 \times 100\%$ |
|------|---------------------------|----------------------|
| 1.0  | 0.0                       | 100.0                |
| 1.1  | 0.2                       | 99.8                 |
| 1.2  | 0.8                       | 99.2                 |
| 1.5  | 4.0                       | 96.0                 |
| 2.0  | 11.1                      | 88.9                 |
| 3.0  | 25.0                      | 75.0                 |
| 4.0  | 36.0                      | 64.0                 |
| 5.0  | 44.4                      | 55.6                 |
| 5.83 | 50.0                      | 50.0                 |
| 10.0 | 66.9                      | 33.1                 |

A common way to find the proper feed location along a dipole or monopole is to feed off-center, which provides increase of the input impedance with respect to the center-feed impedance according to equation (10.14). The input resistance of a half-wavelength dipole is approximately  $73 \Omega$ , which is well suited for standard coaxial lines. The quarter-wavelength monopole has an input resistance of approx.  $37 \Omega$ , and, usually the sleeve-type of feed is used to achieve greater values of the antenna input impedance. The folded dipole is excellent to feed with  $300 \Omega$  twin-lead line.

However, the off-center feed is unsymmetrical and can lead to undesirable phase reversal in the antenna if  $l > \lambda/2$ . This will profoundly change the radiation pattern. To avoid such cases, symmetrical feeds for increased impedance are used.

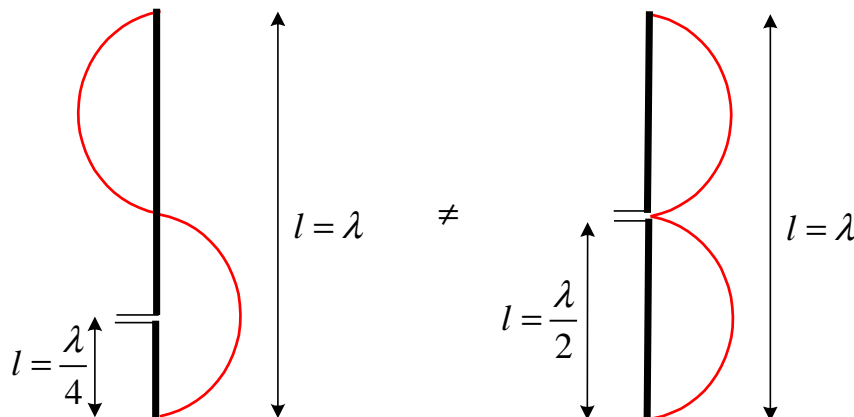

A few forms of shunt matching (or shunt feed) are shown below:

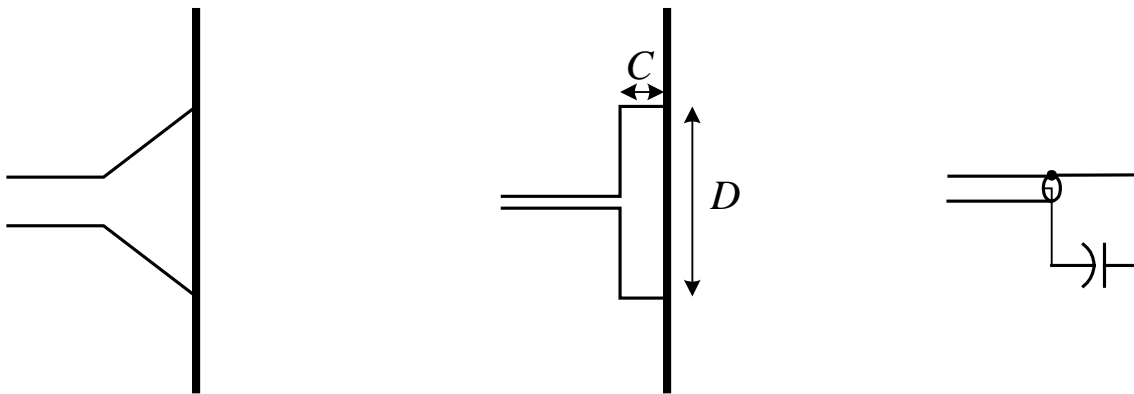

(a) Delta match

(b) Tee match

(c) Gamma match

We shall explain the principles of operation of the T-match only, which is the simplest of all to design and which gives the basic idea for all shunt feeds. The T-match interconnection can be viewed as two shorted transmission lines and a very-wide-gap dipole in parallel with respect to the twin-lead cable. The shorted transmission lines are less than quarter-wavelength long, and, therefore they have an inductive reactance. This reactance is usually greater than the capacitive reactance of the wide-gap dipole, and an additional tuning lumped capacitor might be used to achieve better match. As the distance  $D$  increases, the input impedance increases, too. It has a maximum at about  $D = l/2$  (half the dipole's length). Then, it starts decreasing again, and when  $D = l$ , it equals the folded-dipole input impedance. In practice, sliding contacts are made between the shunt arms and the dipole for impedance adjustments and tuning. Note that shunt matches may radiate, which is very undesirable at the operating frequency band.

The Gamma-match is essentially the same as the T-match, only that it is designed for unbalanced-balanced connection.

Additional matching devices are sometimes used such as quarter-wavelength impedance transformers, reactive stubs for compensating antenna reactance, etc. These devices are well studied and described in courses in Microwave Engineering.

## 5.2. Balanced-to-unbalanced feed

Sometimes when high-frequency devices are connected, their impedances (in a quasi-static sense) might be well matched, and still one might observe significant reflections. This is sometimes referred to as “field mismatch”. A typical example in antenna technology is the interconnect between a coaxial line of  $Z_c = 75 \ \Omega$  and a half-wavelength dipole of  $Z_{in} = 73 \ \Omega$ . The reflections are much more severe than one would predict using equation (10.26). This is because the field and the current distributions in the coaxial line and at the input of the wire dipole are very different.

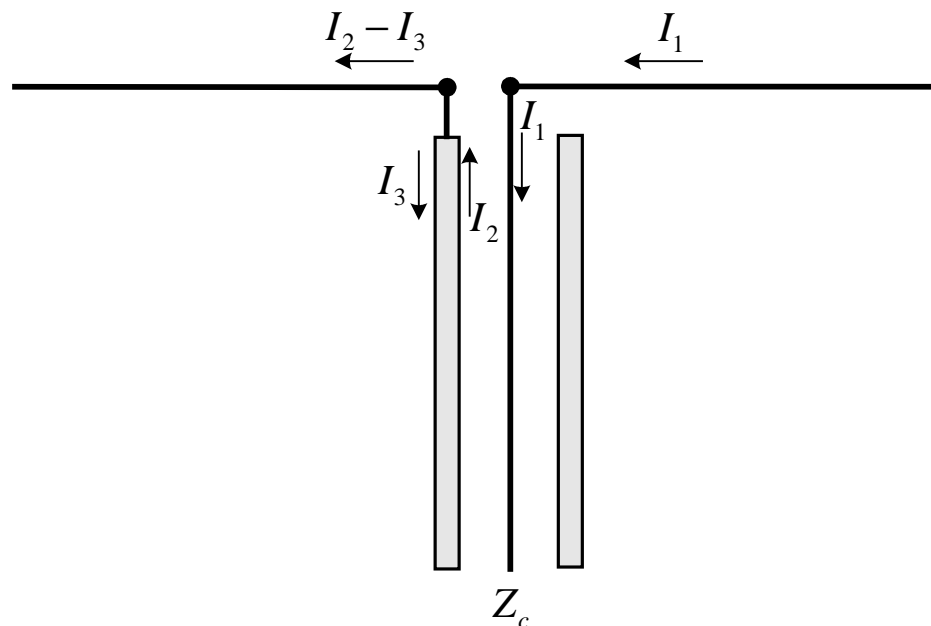

The unequal currents at the dipole's legs unbalance the antenna and the coax. To balance the currents, various devices are used, called baluns (balanced-to-unbalanced transformer).









