

HALF - LOOP ANTENNAS FOR HF COMMUNICATIONS IN ALE AND FREQUENCY HOPPING



<http://perso.wanadoo.fr/starec>

Jean-Pierre GOUIN & Daniel LAFARGUE

STAREC S.A.
7, chemin de Vaubesnard
91410 Dourdan FRANCE
e-mail: starec@wanadoo.fr

Credit Line: Starec

<http://perso.wanadoo.fr/starec>

The present describes a HF loop antenna and its agile coupler which can be adapted to the new designs of ALE and FH (frequency hopping) radiosets. The original specification in 1993 was : "a small mobile antenna and coupler for HF voice and data communications in driving from 0 to 600 km without silent zone, in association with a 125 Watts CW radioset.

Frequency range 2-12 MHz Channel tuning time < 5ms Bandwidth > 3,5 kHz in a military environment" Following on from this product other versions with wider frequency range (3-15 MHz, 3-30 MHz, 2-30 MHz), a higher power and various dimensions and shapes for fixed, land-mobile and naval applications have been developed.

1. GENERALITIES

1.1. on the HF tuned loops

The HF transmission tuned loop antennas which are designed for HF transmission have small dimensions ($< 0,1\lambda$) compared to the wavelength, in order to conduct a quasi constant current and to be considered as magnetic dipoles. Their radiation impedance and efficiency mainly depends on their surface which creates a magnetic flux in the near field and an electromagnetic field in the far field. Their diameter, height or width (round or square shape) run from 1 to 3 meters, and their radiating surface generally do not exceed 5 m^2 in order to coincide with the small dimensions required.

These types of antennas differ from open antennas (like whips, horizontal dipoles, log-periodic antennas,) by their impedance which is reactive and can be adapted by capacitor only. Their radiating resistance is low ($< 1 \text{ m}\Omega$) at the lowest frequencies of the range. As the efficiency is given by the ratio radiating resistance/ total resistances of the tuned circuit, it is necessary to minimise the radiating element resistor, using a good conductive metal (aluminium, copper), and to use low loss capacitors.

These conditions being fulfilled, the loop antennas deliver a high current and have a high selectivity with a high quality factor (Q-factor), typically 10 times higher than the Q-factor of the best traditional couplers designed for 5 to 10 meters whips or 10 to 40 m dipoles.

1.2 On fast frequency tuning

For future fast ALE procedures the tuning target time is 50ms, while the "low speed" frequency hopping (F.H.) procedures already require a 5ms tuning time, with all calculations and control exchange times being included or already done. This can't be done using electromechanical tuning. Digital switching devices are cost effective today at low and medium powers. Their switching time run in milliseconds using low loss vacuum relays, and in the microseconds using electronic relays like PIN-diodes. But the PIN-diode technology cannot be used in loops for transmission, due to their inability to withstand the high currents and due to the losses they bring (0.5 to 1 W) which would drastically decrease the overall efficiency at the lowest frequencies. Vacuum relays, including REED relays, are the only technologies available to switch the capacitors of a transmission tuned loop antenna efficiently.

1.3 On the power requirements

Based on the experience of 2 previous generations of tuned loop antennas, and the proprietary propagation simulations, it was calculated that two 100W radiosets and 4m^2 loops having a -15 to + 5dBi typical gain figure from 2 to 12 MHz would insure voice and data communications at any distance from 0 to to 600 km at least.

This mission cannot be fulfilled by any 5 to 10 m whip antenna on a medium soil, even in association with a 400W/1 kW radio set: a vertical whip or a bent whip on a vehicle in move do not transmit and receive enough energy to cover the typical 50-250 km silent zone.

A 125W radioset combined with a tuned loop antenna is sufficient to fulfill the mission requirement using the Near Vertical Incident Signal (NVIS propagation). This will be further improved due to frequency management and the new generations of HF modems which will bring a lower threshold of sensibility.

II DEVELOPMENT OF A NEW MOBILE TUNED FRAME ANTENNA

II.1 Principle

The mobile tuned loop antenna is a "half-loop" set-up vertically on a metal surface which achieves a full loop equivalence. The metal surface like a mobile platform (truck or shelter, ship's cabin,...) must have a good electrical continuity. This half-loop is half the size of a full loop and makes installation possible on small vehicles on the move.

The half-loop is folded and joined at each end to the platform's earth. One end is loaded by a variable capacitor.

A feed rod ("the feed coil") links the radioset RF access to a precise point of the half-loop. It is equivalent to a fixed reactive element, and the whole system acts as a loss-free autotransformer whose primary circuit can be set to 50 W.

II.2 Modelisation of the antenna

The modelisation purpose is the definition of the electrical circuit and the parameters of the antenna. It is made by the wire methods of moments.

The radiating element is represented by a radiating impedance (R_r, L_a) with a loss resistance R_p

The tuning capacitor is represented by a serial circuit (C, R_c), C being the capacitor value and R_r its loss resistance.

The 50Ω matching is figured by a loss-free transformer M with a matching ratio K , and a parallel or serial inductance L at the RF input.

Establishment of the equivalent circuit parameters:

- The radiating element (R_r, L_a) is calculated by an electromagnetism software based upon the method of moments.
- The radiating element loss R_p is determined according to the antenna material and section
- The capacitor's losses R_c are determined through the manufacturer's data
- The matching ratio K is a function of the primary to secondary radiating surface ratio

Half-Loop Antennas

- The inductance L is a function of the spiral surface comprised between the feed bar and the platform.

Two types of antennas have been compared, type A and type B, differing by the positions of their capacitors.

II.3. Modelisation of the antenna type A

The capacitor is positioned in the secondary of the transformer, at the end of the line (**FIG 1**).

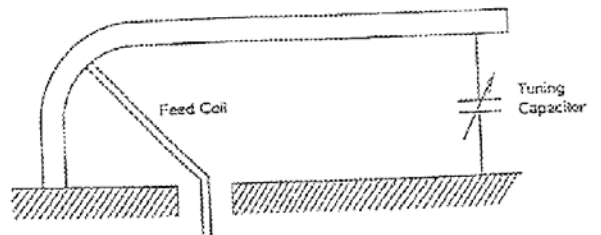

Figure 1

The electrical equivalent scheme is given **FIG 2**

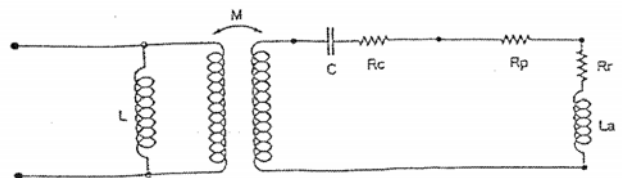
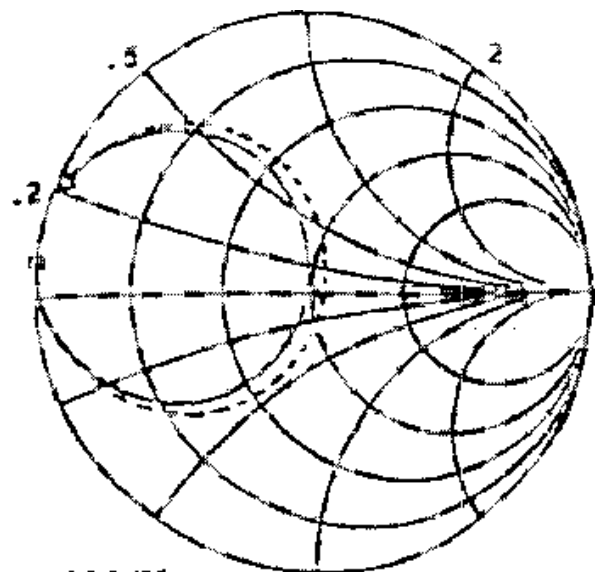

Figure 2

The results are computed by a specific C.A.D. radiofrequency device and compared to the values measured on full scale antenna mock-up.

As an example, **FIG 3, FIG 4, FIG 5** show the



F1: 2.00 MHz
F2: 2.10 MHz

Figure 3

impedances at various frequencies on the Smith charts, with computed values (in full line) and measured values (in dotted lines). These charts underscore the performances of a resonating cavity like a R, L, C parallel device, and confirm the impedance values computed by the method of moments.

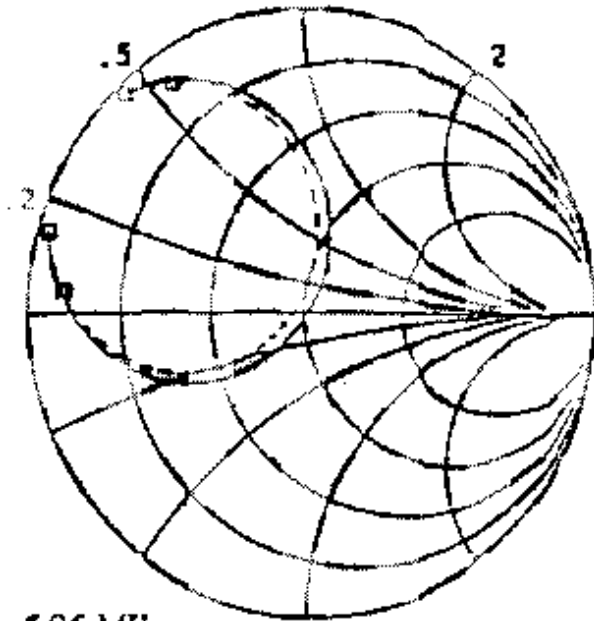

F1: 5.95 MHz
F2: 6.05 MHz

Figure 4

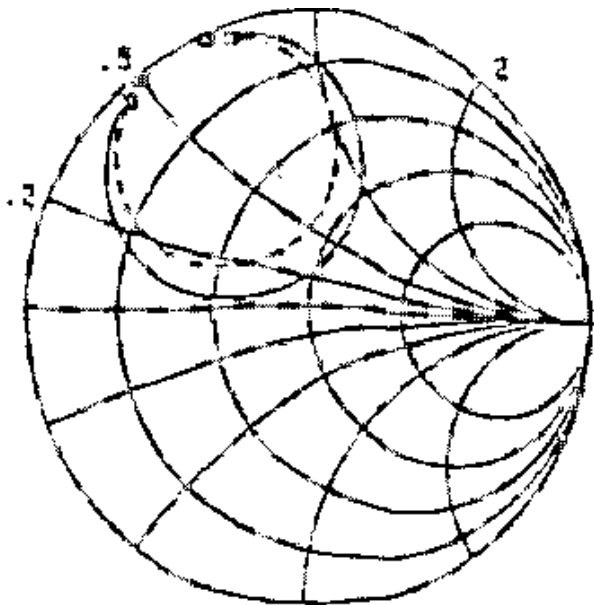

F1: 11.50 MHz
F2: 12.50 MHz

Figure 5

Half-Loop Antennas

The calculated and measured values are compared at various frequencies (FIG 6, FIG7) The bandwidth is measured at VSWR \leq 2.5:1 , when the real and the imaginary terms of the impedance are equal.

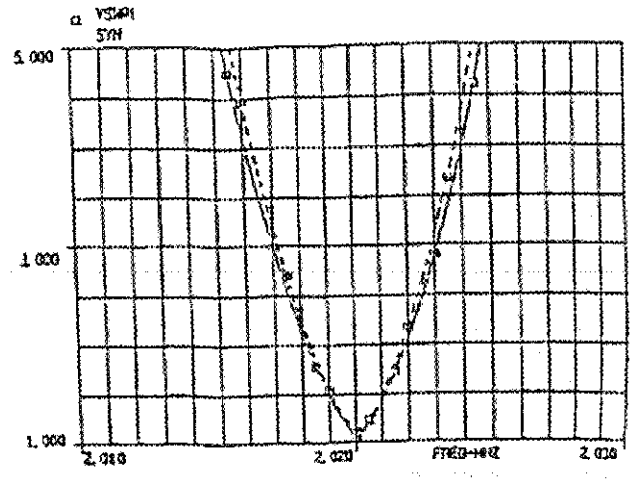

Figure 6

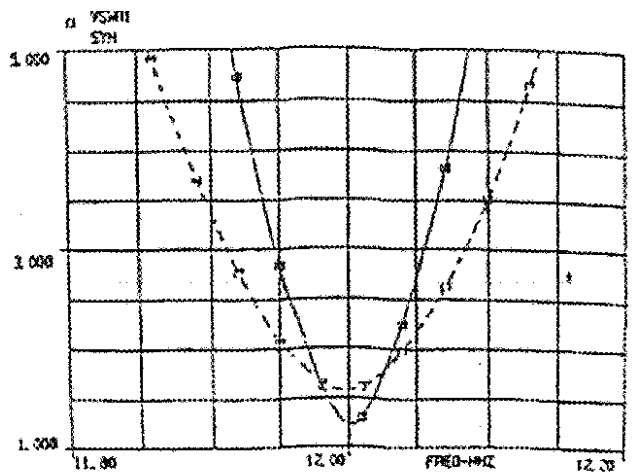

Figure 7

The results have validated the antenna equivalent circuit.

This scheme helped to optimize the dimensions of the radiating element, considering the efficiency and bandwidth requirements. The approximative values are, from 2 to 12 MHz:

$R_r = 0,5m\Omega$ to 3Ω with a $2,2m^2$ antenna surface

$R_p = 0.01$ to 0.02Ω

$C = 3500$ to 60 pF

$R_c = 0.05$ to 2Ω

The equivalent circuit aided in the calculation of the voltages and the currents developed over each electronic component.

II. 4. Modelisation of the antenna type B

The tuning capacitor is positioned in the primary of the autotransformer (FIG 8).



Figure 8

Its equivalent electrical scheme is given on FIG 9.

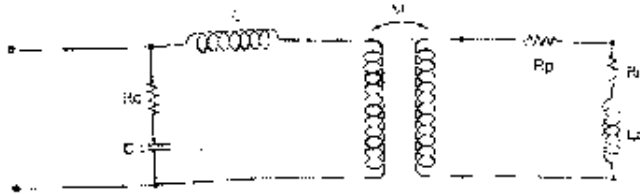

Figure 9

The Type B antenna is modeled in the same way as the Type A antenna, and using the same physical parameters. An additional capacitor may be added in the feed rod to optimize the radioset matching impedance.

II.5. Compared performances type A and type B antennas

Comparative simulations

The compared simulations gave a clear advantage to the Type A antenna type. As an example, FIG 10 shows a +12 dB gain advantage for the Type A antenna at 12 MHz

Comparative measurements

The comparative simulated results were confirmed by the comparative measured bandwidths Using 2 antennas having the same radiating surface, the compared measured bandwidths were 5 to 10 times

Half-Loop Antennas

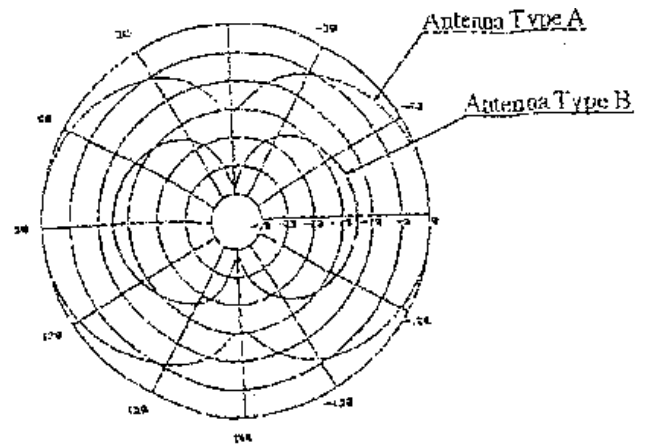

Figure 10

higher for the Type B than for the Type A antenna. In a tuned circuit, bandwidths (B) are inversely proportional to the quality factor (Q), and Q is proportional to the efficiency (h); when $Q \gg 1$, $h \times B = Rr/2p La = \text{constant}$ If h_a and h_b are the Type A and Type B antenna efficiencies , and B_a et B_b their bandwidths respectively, the applying formulas are $h_a B_a = h_b B_b$, and $h_a / h_b = B_b / B_a$ When the measured bandwidth ratios is $B_b / B_a = 10$, the efficiency ratio becomes h_a/h_b is 10.

Explanation

Observing that Type B antenna optimizes the tuning in the primary circuit, and that the Q-factors of primary and secondary are quite different, the energy transfer in the secondary is not maximized. On the contrary, in the Type A antenna the tuning brings a maximum Q-factor and the current is the highest in the radiating resistor.

Conclusion

The Type A antenna design brings the best antenna efficiency.

II.6 Improvement of the design

Increasing the bandwidth

Trials on vehicles were made under strong rain. Modifications of the tune positions were observed at the highest frequencies (FIG 11)

Such modifications can give an operational problem with no possible reset in transmission (in FH mode principally).

This shifting problem was resolved by widening the bandwidth by using two radiating elements in parallel and electrically linked. The simulation of this structure

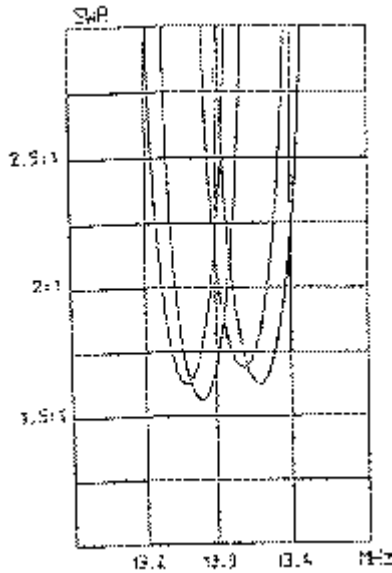

Figure 11

modification concluded in a +10 to +15% extended bandwidths and in +0.5dB to +1dB extra efficiencies all over the frequency range.

II.7. Realisation of a fast tune design

The 2-12 MHz. antenna was developed for the required efficiency and a minimum 3.5 kHz bandwidth independently of the variations in the environment.

With a 2.2m² radiating surface the half-loop reactance is 2mH at 2 MHz and 3.5mH at 12 MHz.

The tuning principle consists in switching capacitors in parallel to create a series of bandwidths with mutual covering at a VSWR < 2.5:1.(FIG 12)

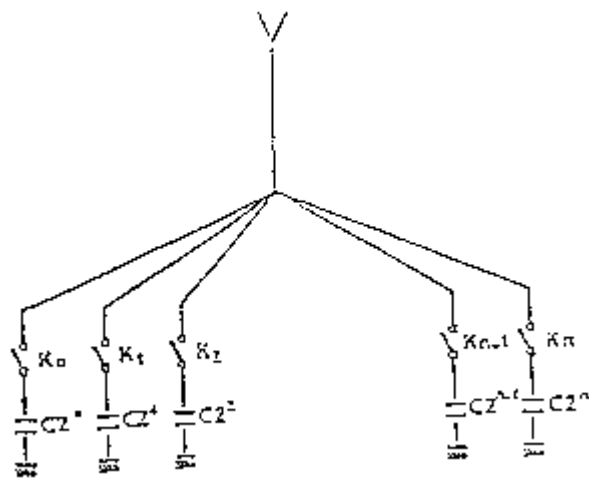

Figure 12

Principle of the capacitor switching

The capacitors which are necessary to tune the antenna reactance are scaled from 3300pF to 60 pF at 2 MHz and 12 MHz respectfully, with a 1,5 pF accuracy at the highest frequencies.

A logarithmic series of n switchable capacitors in parallel defined by $C_i = 2 C_{i-1}$ with $C_1 = 1.5$ pF give all discrete value multiple of 1,5pF:

$$C = S \cdot k_i \cdot C_i \text{ from } i = 1 \text{ to } n, \text{ with } k_i = 0 \text{ ou } 1$$

C1, which is the smallest used capacitor, defines the accuracy of the C capacitor

The highest individual capacitor value is in theory $3300/2 = 1650$ pF in order to get 3300pF by the addition of all capacitors, and n must be higher than 10.

The total number of capacitors is chosen equal to 12 to take into consideration the dispersion of the components whose values are guaranteed with a $\pm 5\%$ precision, and to recover the possible missing frequency bands.

A special software was created to define and memorize the $k_i C_i$ arrangements which are necessary to get all discrete capacitor values and recover the possible missing frequency bands. It memorizes the calculated values and the measured values. A calibration at the first installation or in operation in case of a major environment change can be done in less than 6 seconds.

Measured results

The prototype of the antenna achieved a VSWR 2.5:1.

Typical figures are given FIG13.

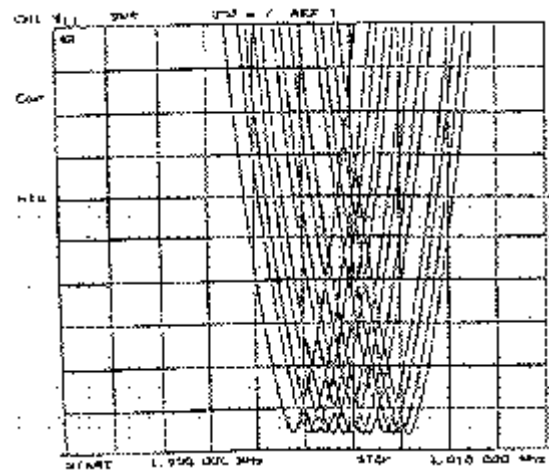

Figure 13

II.7. Qualification

A 2-12 MHz demonstrator was built with acceptable dimensions for land mobile applications (height=90cm, length=2.4m, width=30cm). All adjacent bandwidths were covered within the 2.5:1 VSWR specification.

Its efficiency was measured every 0.5 MHz on a test station by substitution of a reference whip. These values were not more different than ± 1 dB from the values deducted from the Q-factor measurements.

A second version with a 2-30MHz frequency range was developed. It was qualified for military environment with mechanical tests (chocks, vibrations) and climatic tests (-40C +70C, rainfall, salted fog, windspeed, ice, dusts, etc...) according to MIL SPEC standards. It is now in service in quantities in the French Army.

III FIELD TRIALS

Extract from the field trial made by Thomson-CSF in October 1994 for the French Army:

"From 0 to 600 km, all Q/S and S+N/N measurements have confirmed a behaviour without fault of the half-loop. It always gave results much higher than that of the guyed 5m whip whatever the climatic conditions were (rain, intensive fog...). We tried to use the station in the most extreme environment conditions noting the link results, while driving under the rain, under the high voltage cables either parallel or perpendicular to the road, measuring signal/noise in highly industrialized towns (like Clermont Ferrand) , on the country roads through humid forests, etc...

"The results were independent of these environmental conditions, the reception signal/noise being only slightly affected under the very high voltage cables.

"...The half-loop antenna brings the best results in terms of link budget and listening comfort".

Thomson-CSF also confirmed that the half-loop antenna on a moving car allows fast data transmissions without fault in the silent zone of the whip antenna, and that it improves the probability of successful synchronisation of the new procedures in bad ionospheric conditions.

Other field trials were successfully conducted in France and several foreign countries in the Middle East and America.

IV RADIO INTERFACES

Mobile and naval half-loop antennas and fixed/semi-fixed loop antennas using the same electronic components and softwares are working today with various radiosets for military and civilian applications as well, in frequency hopping, ALE or fixed frequency modes. A modular and universal interfacing unit makes it possible to fit the antenna at the radio set RF output using the control interfacing designed for its antenna coupler.

The control exchanges can be done in RS232 or multiwire cable according to the speed. The frequencies can be provided in clear, as a channel number or not provided at all. A frequency counter is necessary in this last configuration.

(Continue on the next page)

MILITARY TACTICAL ANTENNAS

STAREC has been involved for a long time in the design of specialized antennas, a wide range of which has been proved in operation with French and foreign Armed Forces.

This equipment is mainly used in fixed or mobile weapons or telecommunication systems, such as shelters, trucks, battle tanks, forward armoured vehicles, etc. STAREC is involved in the RITA, ROLAND, PR4 G, HF Carthage programs.

Agile half loop on vehicle



<http://perso.wanadoo.fr/starec>

V APPLICATIONS

The chart below present the "not so wellknown" specificities and applications of the HF tuned HF/125W loops and half-loops.

GENERAL CHARACTERISTICS	APPLICATIONS
<p>Very small dimensions for HF (1.5 to 3m rectangle or diameter) Can be radomed</p>	<p>Difficult installations (on roof, small areas, ship,...) Half-loop capability to communicate from a moving vehicle. Discrete stations (fixed and mobile)</p>
<p>Small surface on ground.A ground plane is not necessary for loop</p>	<p>Easy and low cost installation.</p>
<p>Low take-off angle propagation andGround wave radiation (8-shaped pattern)+Near Vertical Incidence Skywave (NVIS) Directivity: + 2dB in free space and +5dB or +6 dB on a conductive ground Gain: - 12/-15 dBi at lowest frequencies to+ 2/+ 5 dBi at highest frequencies.</p>	<p>Communications up to 1000km with 125W, without silent zone in azimuth nor petal nulls in elevation. Communications of the ships along the coasts and over mountains. One antenna only gives the equivalent services of a NVIS antenna (like horizontal dipole) and a vertical whip (at longer ranges). Achievement of an ALE fully automated mobile station: no more need to change antennas at halt alongside the classic silent zone of whips.</p>
<p>High selectivity in the lowest range. High reduction of outband transmissions. High reduction of received noise and improvement of the Signal/Noise ratio(typically 6 to 10dB in reception compared to the wider band antennas like tuned whips or dipoles) High rejection of the strong wideband signals like high voltage lines spurious, indirect effects of lightening, etc... 2 tuned loops are highly isolated (particularly when they are perpendicular with one frame in the central axis of the other one).</p>	<p>Compared to the whip antennas: Better listening comfort, reduced Bit Error Rate (BER) of data transmissions or FH synchronisation signals. Extra filters can be avoided in many applications. Operational in industrial zones and areas of frequent lightning. Simultaneous transmission and reception on the same narrow site (head of a star chained network, duplex station, HF-HF relay,...)</p>
<p>Fully capacitive tuning unit, without coil nor magnetic signature effect</p>	<p>Interesting for certain ships</p>

HF/125W fast tuned frame antennas can find a number of applications for point to point, ground to air and ship to shore applications at any distance to 1000 km.