

*Feel Yourself a Student!*

Dear friends, I would like to give to you an interesting and reliable antenna theory. Hours searching in the web gave me lots theoretical information about antennas. Really, at first I did not know what information to chose for ANTENTOP. Finally, I stopped on lectures "Modern Antennas in Wireless Telecommunications" written by Prof. Natalia K. Nikolova from McMaster University, Hamilton, Canada.

*You ask me: Why?*

Well, I have read many textbooks on Antennas, both, as in Russian as in English. So, I have the possibility to compare different textbook, and I think, that the lectures give knowledge in antenna field in great way. Here first lecture "Introduction into Antenna Study" is here. Next issues of ANTENTOP will contain some other lectures.

***So, feel yourself a student! Go to Antenna Studies!***

I.G.

***My Friends, the Intro was given at ANTENTOP- 01- 2003 to Antennas Lectures.***

***Now I know, that the Lecture is one of popular topics of ANTENTOP- 01 and 02 - 2003. The both Lecture were downloaded more than 1000 times to December, 15!***

***Now I want to present you one more very interesting Lecture - it is a Lecture about Loop Antennas. I believe, you cannot find such info anywhere for free! Very interesting and very useful info for every ham, for every radio- engineer.***

***So, feel yourself a student! Go to Antenna Studies!***

I.G.

*McMaster University Hall*

***Prof. Natalia K. Nikolova***



## **LECTURE 11: Loop Antennas**

*(Radiation parameters of a small loop. A circular loop of constant current. Equivalent circuit of the loop antenna. The small loop as a receiving antenna. Ferrite loops.)*

by Prof. Natalia K. Nikolova

## **LECTURE 11: Loop Antennas**

*(Radiation parameters of a small loop. A circular loop of constant current. Equivalent circuit of the loop antenna. The small loop as a receiving antenna. Ferrite loops.)*

### **Introduction**

Loop antennas form another antenna type, which features simplicity, low cost and versatility. Loop antennas can have various shapes: circular, triangular, square, elliptical, etc. They are widely used in applications up to the microwave bands (up to  $\approx 3$  GHz). In fact, they are often used as electromagnetic (EM) field probes in the microwave bands, too.

Loop antennas are usually classified as electrically small ( $C < 0.1\lambda$ ) and electrically large ( $C \sim \lambda$ ). Electrically small loops of single turn have very small radiation resistance (comparable to their loss resistance). Their radiation resistance though can be substantially improved by adding more turns. Multi-turn loops have better radiation resistance but their efficiency is still very poor. That is why they are used predominantly as receiving antennas, where losses are not so important. The radiation characteristics of a small loop antenna can be additionally improved by inserting a ferromagnetic core. Radio-receivers of AM broadcast are usually equipped with ferrite-loop antennas. Such antennas are widely used in pagers, too.

The small loops, regardless of their shape, have a far-field pattern very similar to that of a small dipole (normal to the plane of the loop), which is to be expected because of the equivalence of a magnetic dipole and a small current loop. Of course, the field polarization is orthogonal to that of a dipole.

As the circumference of the loop increases, the pattern maximum shifts towards the loop's normal, and when  $C \approx \lambda$ , the maximum of the pattern is at the loop's normal.

## 1. Radiation parameters of a small loop

A small loop is a loop of constant current whose radius satisfies

$$a < \frac{\lambda}{6\pi}, \quad (11.1)$$

or, whose circumference  $C$  satisfies  $C < \frac{\lambda}{3}$ . The limit (11.1) is

mathematically derived later in this Lecture from the first-order approximation of the Bessel function of the first order  $J_1(x)$  in the general solution for a loop of constant current. Actually, to make sure that the current has constant distribution along the loop, a tighter limit must be imposed, namely

$$a < 0.03\lambda \quad (11.2)$$

or,  $C < \frac{\lambda}{5}$ . A very good approximation of a small loop is the infinitesimal loop (or the infinitesimal magnetic dipole).

The expressions for the field of an infinitesimal loop of electric current of area  $A$  were already derived in Lecture 3, Section 3. Here, we shall give only the far-field components of the field of an infinitesimal loop whose normal is along the  $z$ -axis:

$$E_\varphi = \eta\beta^2 \cdot (IA) \cdot \frac{e^{-j\beta r}}{4\pi r} \cdot \sin\theta \quad (11.3)$$

$$H_\theta = -\beta^2 \cdot (IA) \cdot \frac{e^{-j\beta r}}{4\pi r} \cdot \sin\theta \quad (11.4)$$

It is now obvious that the far-field pattern

$$\bar{E}_\varphi(\theta) = \sin\theta \quad (11.5)$$

is identical to that of a  $z$ -directed infinitesimal dipole. However, the loop field's polarization is orthogonal to that of the dipole. The power pattern is identical to that of the infinitesimal electric dipole:

$$F(\theta) = \sin^2\theta \quad (11.6)$$

Radiated power:

$$\begin{aligned}\Pi &= \oint\oint \frac{1}{2\eta} |E_\phi|^2 \cdot \underbrace{r^2 \sin\theta d\theta d\phi}_{ds} \\ \Pi &= \frac{1}{12\pi} \eta \beta^4 (IA)^2\end{aligned}\quad (11.7)$$

Radiation resistance:

$$R_r = \eta \frac{8}{3} \pi^3 \left( \frac{A}{\lambda^2} \right)^2 \quad (11.8)$$

In free space,  $\eta = 120\pi$ , and

$$R_r = 31171 \left( \frac{A}{\lambda^2} \right)^2 \quad (11.9)$$

Equation (11.9) gives the radiation resistance of a single loop. If the loop antenna has  $N$  turns, then the radiation resistance increases with a factor of  $N^2$ :

$$R_r = \eta \frac{8}{3} \pi^3 \left( N \frac{A}{\lambda^2} \right)^2 \quad (11.10)$$

The relation in (11.10) provides a very handy mechanism to increase  $R_r$  and the radiated power  $\Pi$ . Unfortunately, the losses of the loop antenna also increase (although only as  $\sim N$ ). Typically, loop antennas have low efficiency, and are preferred as receiving antennas.

Directivity is the same as that of an infinitesimal dipole:

$$D_0 = 4\pi \frac{U_{\max}}{\Pi_{rad}} = 1.5 \quad (11.11)$$

## 2. Circular loop of constant current – general solution

So far, we have assumed that the loop is of infinitesimal radius  $a$ , which allowed us to use the equivalence of the infinitesimal magnetic dipole. Now, we shall derive the far field of a circular loop, which might not be necessarily very small, but still has constant current distribution. This derivation illustrates the general approach to the loop antenna analysis. This approach is used in the solutions to circular loop problems of non-uniform distributions, too.

The circular loop can be divided into infinitely large number of infinitesimal current elements. The position of a current element in the  $x$ - $y$  plane is characterized by  $0^\circ < \varphi' < 360^\circ$  and  $\theta' = 90^\circ$ . The position of the observation point  $P$  is defined by  $(\theta, \varphi)$ .

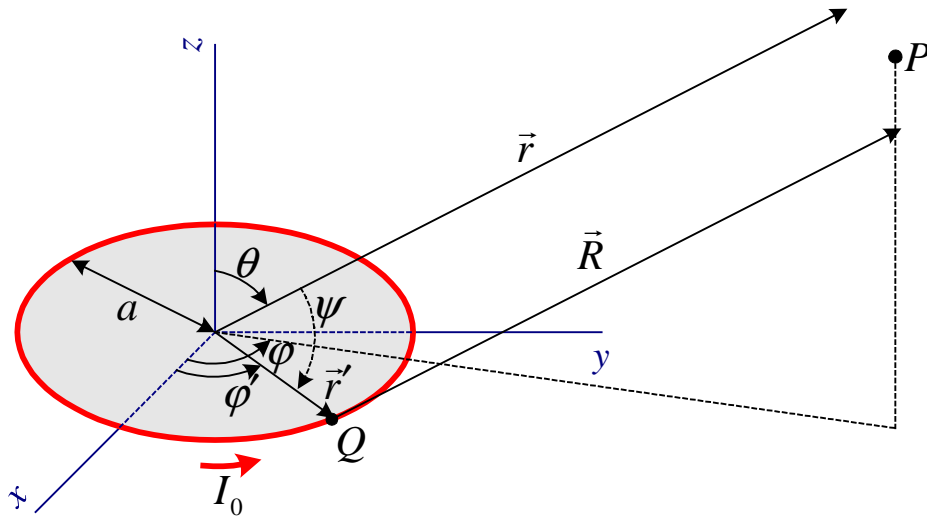

The far-field approximations made are:

$$\left| \begin{array}{l} R \approx r - a \cos \psi, \text{ for the phase term} \\ \frac{1}{R} \approx \frac{1}{r}, \text{ for the amplitude term} \end{array} \right. \quad (11.12)$$

We shall assume that the observation point is at  $\varphi = 0$  for simplicity. In general, the solution for  $\vec{A}$  does not depend on  $\varphi$  because of the cylindrical symmetry of the problem.

$$\begin{aligned}
\cos \psi &= \hat{r} \cdot \hat{r}' = \\
&= (\hat{x} \sin \theta \cos \varphi + \hat{y} \sin \theta \sin \varphi + \hat{z} \cos \theta) \cdot (\hat{x} \cos \varphi' + \hat{y} \sin \varphi') \\
&\Rightarrow \cos \psi = \sin \theta \cos \varphi' \quad (11.13)
\end{aligned}$$

Now, the vector potential integral can be solved for the far zone.

$$\vec{A}(r, \theta, \varphi) = \frac{\mu}{4\pi} \oint_c I_0 \frac{e^{-j\beta(r-a\sin\theta\cos\varphi')}}{r} d\vec{l}, \quad (11.14)$$

where  $d\vec{l} = \hat{\varphi}' a d\varphi'$  is the linear element of the loop contour. The current element changes its direction along the loop, and its contribution will depend on the angle between its direction and the respective  $\vec{A}$  component. The problem is cylindrically symmetrical, and it is appropriate to represent it through the  $A_\varphi$  component because  $\vec{A} = A_\varphi \hat{\varphi}$ .

$$A_\varphi(\theta, \varphi) = \frac{\mu}{4\pi} (I_0 a) \frac{e^{-j\beta r}}{r} \int_0^{2\pi} (\hat{\varphi} \cdot \hat{\varphi}') e^{j\beta a \sin \theta \cos \varphi'} d\varphi' \quad (11.15)$$

Since

$$\begin{aligned}
\hat{\varphi} \cdot \hat{\varphi}' &= (\hat{x} \cos \varphi + \hat{y} \sin \varphi) \cdot (\hat{x} \cos \varphi' + \hat{y} \sin \varphi') = \\
&= \cos \varphi \cos \varphi' + \sin \varphi \sin \varphi' = \\
&= \cos(\varphi - \varphi') \quad (11.16)
\end{aligned}$$

then

$$A_\varphi(\theta, \varphi) = \frac{\mu}{4\pi} (I_0 a) \frac{e^{-j\beta r}}{r} \int_0^{2\pi} \cos(\varphi - \varphi') \cdot e^{j\beta a \sin \theta \cos \varphi'} d\varphi' \quad (11.17)$$

Because of the cylindrical symmetry of  $A_\varphi$ , it was assumed that  $\varphi = 0$ .

$$A_\varphi(\theta) = \frac{\mu}{4\pi} (I_0 a) \frac{e^{-j\beta r}}{r} \int_0^{2\pi} \cos \varphi' \cdot e^{j\beta a \sin \theta \cos \varphi'} d\varphi' \quad (11.18)$$

$$A_\varphi(\theta) = \frac{\mu}{4\pi} (I_0 a) \frac{e^{-j\beta r}}{r} \left[ \int_0^\pi \cos \varphi' \cdot e^{j\beta a \sin \theta \cos \varphi'} d\varphi' + \int_\pi^{2\pi} \cos \varphi' \cdot e^{j\beta a \sin \theta \cos \varphi'} d\varphi' \right]$$

One can apply the following substitution in the second integral:  $\varphi' = \varphi'' + \pi$ . Then:

$$A_\varphi(\theta) = \frac{\mu}{4\pi} (I_0 a) \frac{e^{-j\beta r}}{r} \left[ \int_0^\pi \cos \varphi' \cdot e^{j\beta a \sin \theta \cos \varphi'} d\varphi' - \int_0^\pi \cos \varphi'' \cdot e^{-j\beta a \sin \theta \cos \varphi''} d\varphi'' \right] \quad (11.19)$$

The integrals in (11.19) can be expressed in terms of the Bessel functions, which are defined as:

$$\int_0^\pi \cos(n\varphi) e^{jz \cos \varphi} d\varphi = \pi j^n J_n(z) \quad (11.20)$$

Here,  $J_n(z)$  is the Bessel function of the first kind of order  $n$ . From (11.19) and (11.20) it follows that:

$$A_\varphi = \frac{\mu}{4\pi} (I_0 a) \frac{e^{-j\beta r}}{r} \pi j \left[ J_1(\beta a \sin \theta) - J_1(-\beta a \sin \theta) \right] \quad (11.21)$$

Since

$$J_n(-z) = (-1)^n J_n(z) \quad (11.22)$$

equation (11.21) reduces to

$$A_\varphi = j \frac{\mu}{2} (I_0 a) \frac{e^{-j\beta r}}{r} J_1(\beta a \sin \theta) \quad (11.23)$$

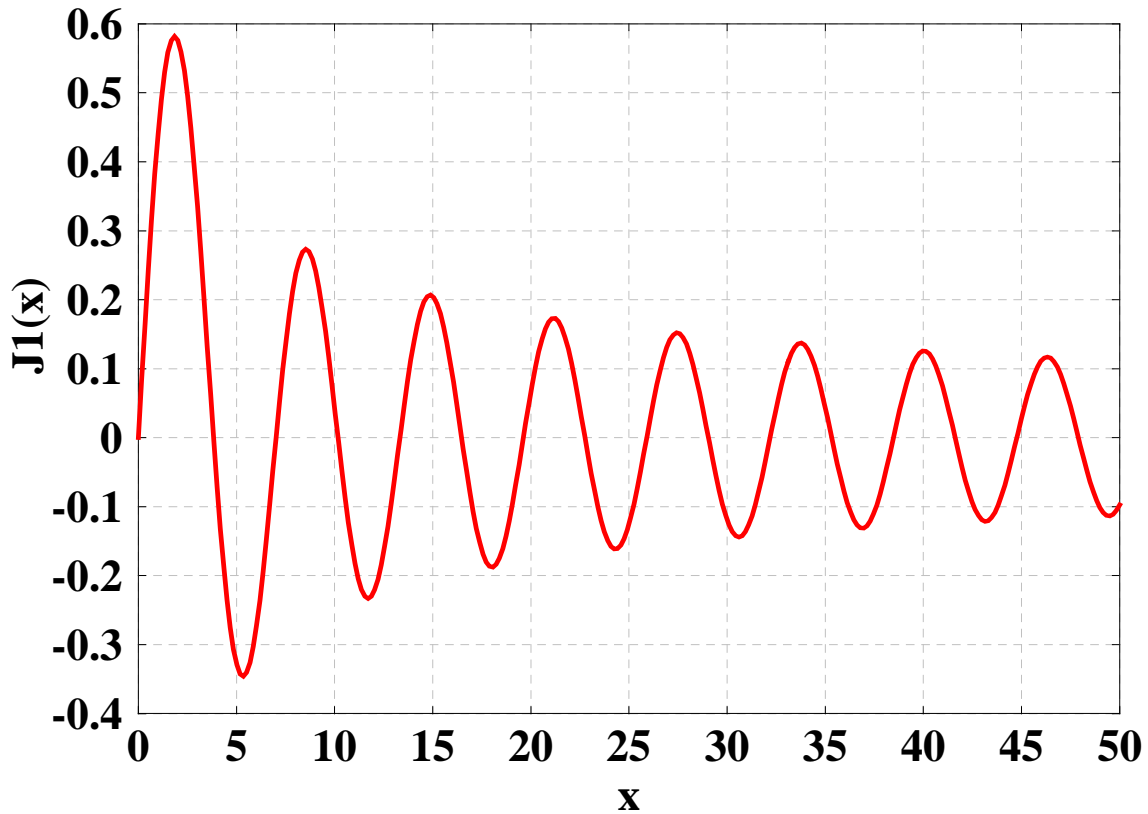

The far-zone fields are derived as:

$$\begin{cases} E_\phi = \beta\eta(I_0a) \frac{e^{-j\beta r}}{2r} J_1(\beta a \sin \theta) \\ H_\theta = -\frac{E_\phi}{\eta} = -\beta(I_0a) \frac{e^{-j\beta r}}{2r} J_1(\beta a \sin \theta) \end{cases} \quad (11.24)$$

The patterns of constant-current loops corresponding to (11.24):

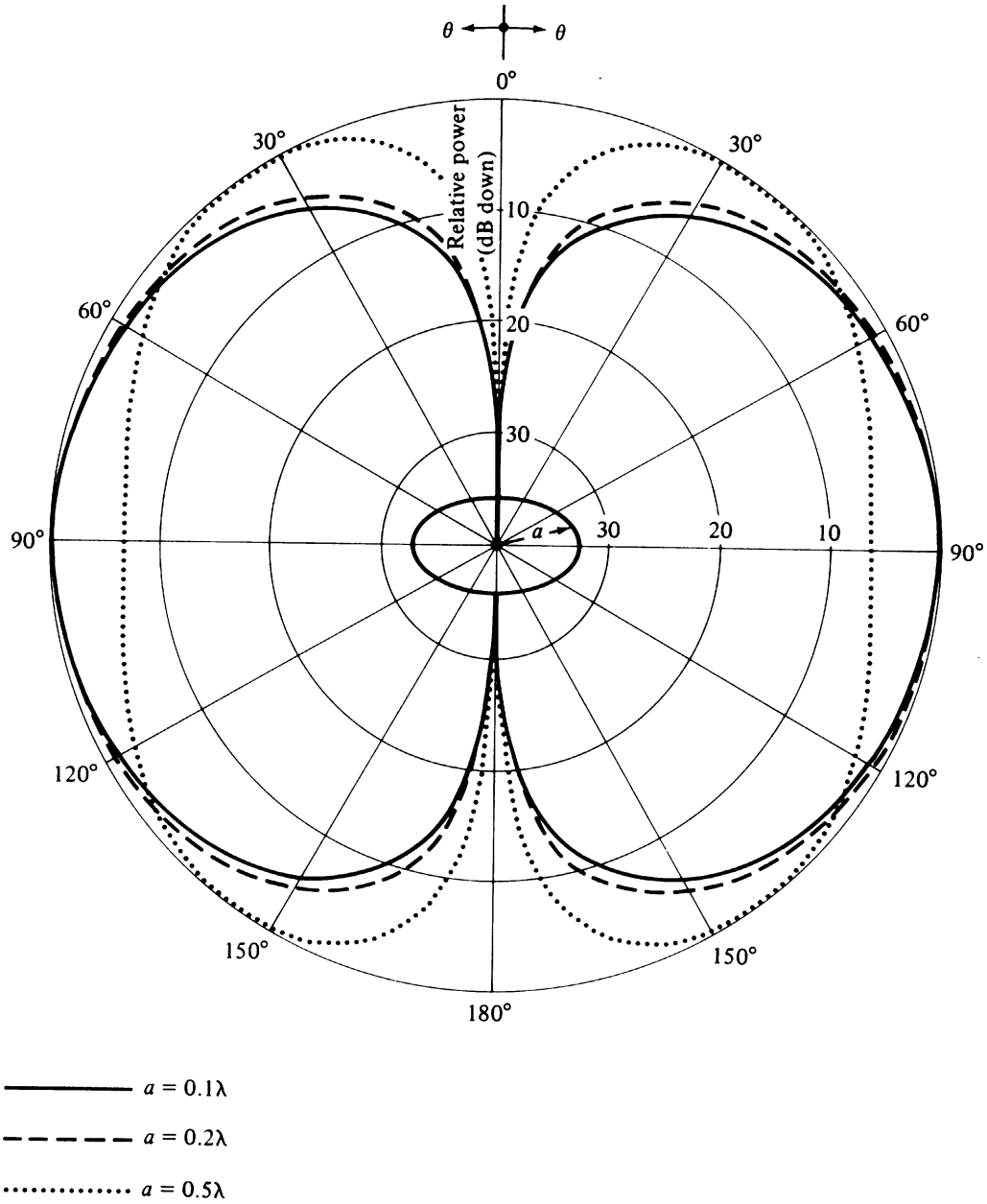



The small-loop field solution in (11.3)-(11.4) is actually a first order approximation of the solution in (11.24). This becomes obvious when the Bessel function is expanded into series as:

$$J_1(\beta a \sin \theta) = \frac{1}{2}(\beta a \sin \theta) - \frac{1}{16}(\beta a \sin \theta)^3 + \dots \quad (11.25)$$

For small values of the argument ( $\beta a < 1/3$ ), the first-order approximation is acceptable, i.e.

$$J_1(\beta a \sin \theta) \approx \frac{1}{2}(\beta a \sin \theta) \quad (11.26)$$

Substituting (11.26) in (11.24) yields (11.3)-(11.4).

It can be shown that the maximum of the pattern given by (11.24) is in the direction  $\theta = 90^\circ$  for all loops, which have circumference  $C < 1.84\lambda$ .

### Radiated power and radiation resistance

Substituting in

$$\Pi = \oint\oint \frac{1}{2\eta} |E_\varphi|^2 \cdot \underbrace{r^2 \sin \theta d\theta d\varphi}_{ds}$$

the  $E_\varphi$  expression in (11.24), yields

$$\Pi = \frac{(\omega\mu)^2}{4\eta} (I_0^2 A) \int_0^\pi J_1^2(\beta a \sin \theta) \sin \theta d\theta \quad (11.27)$$

where  $A = \pi a^2$  is the loop's area. The integral in (11.27) does not have a closed form solution. Often, the following transformation is applied:

$$\int_0^\pi J_1^2(\beta a \sin \theta) \sin \theta d\theta = \frac{1}{\beta a} \int_0^{2\beta a} J_2(x) dx \quad (11.28)$$

The second integral in (11.28) does not have a closed form solution either but it is easier to approximate.

The radiation resistance is obtained as:

$$R_r = \frac{2\Pi}{I_0^2} = \frac{(\omega\mu)^2}{2\eta} A \cdot \int_0^\pi J_1^2(\beta a \sin \theta) \sin \theta d\theta \quad (11.29)$$

The radiation resistance of small loops is very small. For example, for  $\frac{\lambda}{100} < a < \frac{\lambda}{30}$  the radiation resistance increases from  $\approx 3 \times 10^{-3}$  up to  $\approx 0.5 \ \Omega$ . This is often less than the loss resistance of the loop. That is why small loop antennas are constructed with multiple turns and on a ferromagnetic core. They, of course, have much greater inductive reactance, which is always compensated by a capacitor. This is actually used in narrowband receivers, where the antenna itself is a very efficient filter (together with the tuning capacitor), which can be tuned for different frequency bands.

### 3. Circular loop of non-uniform current

When the loop radius becomes larger than  $0.2\lambda$ , the constant-current assumption does not hold. A common assumption is the cosinusoidal distribution. However, even this one is not satisfactory, especially close to the terminals. That is why the current is often represented by a Fourier series<sup>1</sup>:

$$I(\varphi') = I_0 + 2 \sum_{n=1}^N I_n \cos(n\varphi') \quad (11.30)$$

The complete analysis of this general case will be left out, and only some important results will be given. When the circumference of the loop approaches  $\lambda$ , the maximum of the radiation pattern shifts exactly along the loop's normal. Then, the input resistance of the antenna is also acceptable (about  $50 - 70 \ \Omega$ ). The maximum directivity occurs when  $C \approx 1.4\lambda$  but then the input impedance is too large. The large circular loop input resistance and reactance are given below.

---

<sup>1</sup> E.A. Wolff, *Antenna Analysis*, Wiley, New York, 1966.

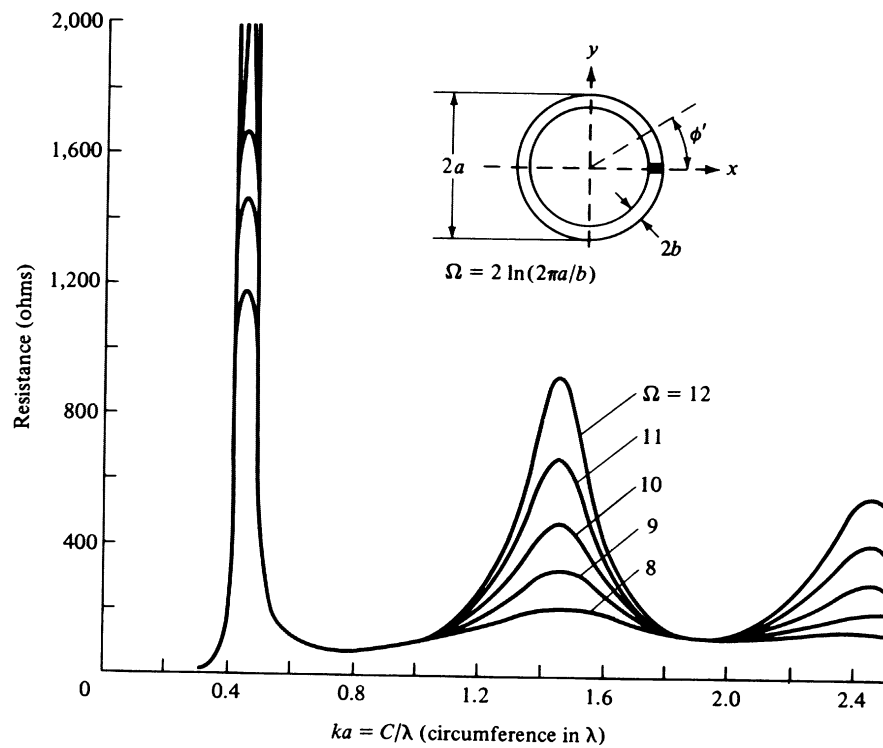

(a) Resistance

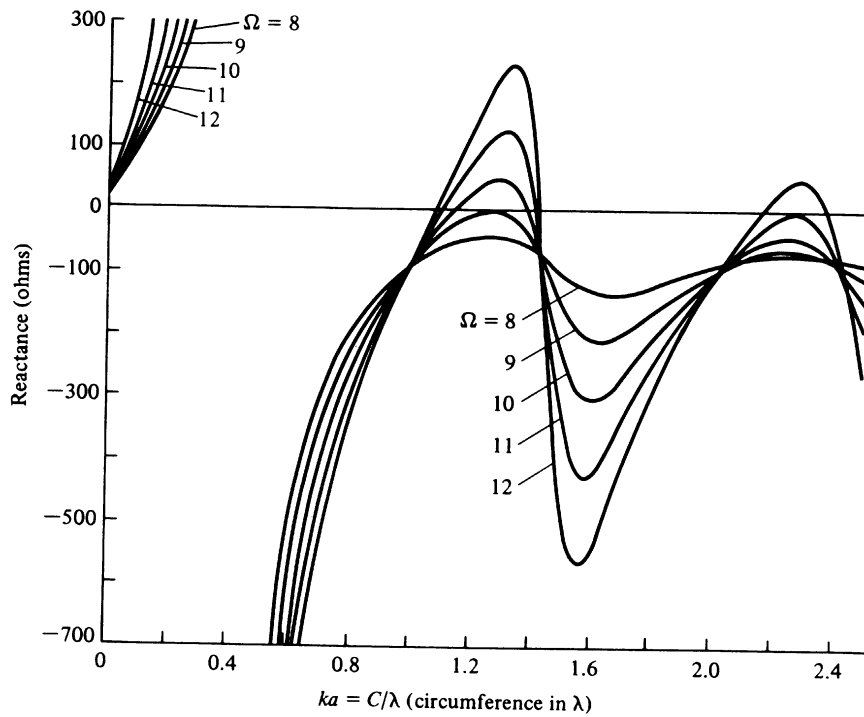

(b) Reactance

**Figure 5.11** Input impedance of circular loop antennas. (SOURCE: J. E. Storer, "Impedance of Thin-Wire Loop Antennas," *AIEE Trans.*, Vol. 75, November 1956. © 1956 IEEE).

The large circular loop is very similar in its performance to the large square loop. An approximate solution of very good accuracy for the square-loop antenna can be found in

W.L. Stutzman and G.A. Thiele, *Antenna Theory and Design*, 2<sup>nd</sup>. Ed., John Wiley & Sons, New York, 1998

There, it is assumed that the total antenna loop is exactly one wavelength and has a sinusoidal distribution along the loop.

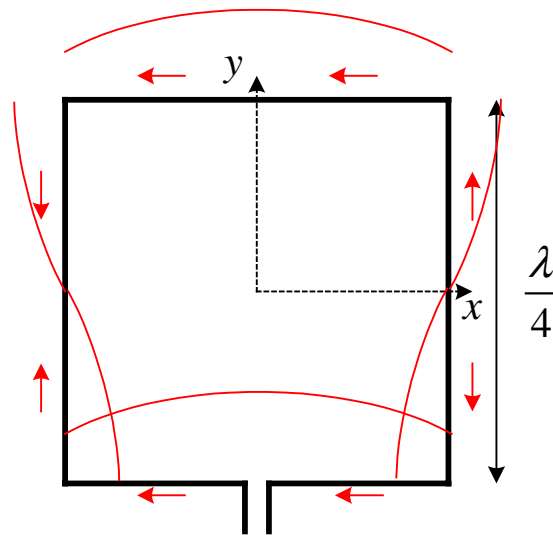

Principal plane patterns obtained through the sinusoidal-current assumption and using numerical methods:

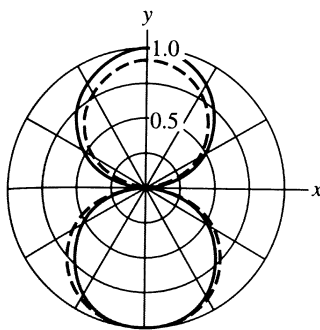

(a) The  $xy$ -plane (the plane of the loop and an  $E$ -plane) normalized pattern plot of  $E_\phi$ . In this plane,  $HP = 94^\circ$ .

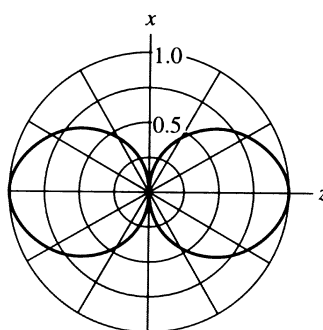

(b) The  $xz$ -plane (an  $E$ -plane) normalized pattern plot of  $E_\theta$ . In this plane,  $HP = 85^\circ$ . The patterns from the two methods coincide in this plane.

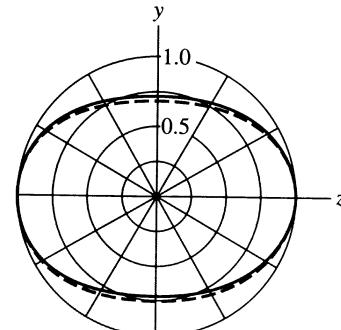

(c) The  $yz$ -plane (the  $H$ -plane) pattern plot of  $E_\phi$ .

#### 4. Equivalent circuit of a loop antenna

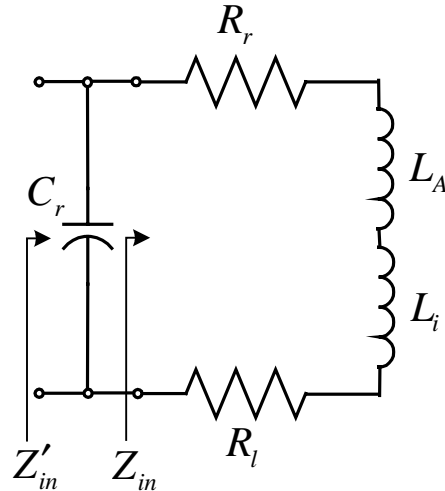

- $C_r$  - resonance capacitor
- $R_l$  - loss resistance of the loop antenna
- $R_r$  - radiation resistance
- $L_A$  - inductance of the loop
- $L_i$  - inductance of the loop conductor (wire)

##### (a) Loss resistance

Usually, it is assumed that the loss resistance of the loop equals the high-frequency loss resistance of a straight wire of the same length as the loop and of the same current distribution. In case of a uniform current distribution, the high-frequency resistance is calculated as:

$$R_{hf} = \frac{l}{p} R_s, \quad R_s = \sqrt{\frac{\pi f \mu}{\sigma}}, \quad \Omega, \quad (11.31)$$

where  $l$  is the length of the wire, and  $p$  is the perimeter of the wire's cross-section. We shall not be concerned with the current distribution now because it can be always taken into account in the same way as it is done for the dipole/monopole antennas. However, another important phenomenon has to be taken into account, namely the so-called *proximity effect*.

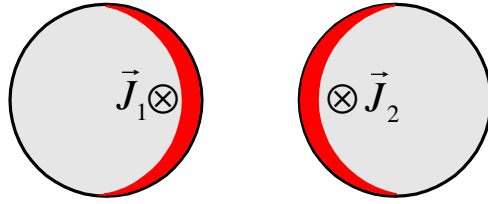

When the spacing between the wires is very small, the loss resistance due to the proximity effect might be larger than that due to the skin effect. The following formula is used to calculate exactly the loss resistance of a loop with  $N$  turns, wire radius  $b$ , and loop separation  $2c$ :

$$R_l = \frac{Na}{b} R_s \left( \frac{R_p}{R_0} + 1 \right) \quad (11.32)$$

where

$R_s$ ,  $\Omega$ , is the surface resistance (see (11.31))

$R_p$ ,  $\Omega/\text{m}$ , is the ohmic resistance per unit length due to proximity effect

$R_0 = \frac{NR_s}{2\pi b}$ ,  $\Omega/\text{m}$ , is the ohmic resistance per unit length due to skin effect.

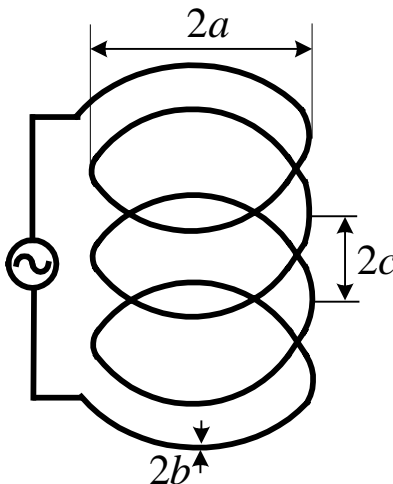

The ratio  $R_r / R_0$  has been calculated for different relative spacings  $c/b$ , for loops with  $2 \leq N \leq 8$  in:

G.N. Smith, "The proximity effect in systems of parallel conductors," *J. Appl. Phys.*, vol. 43, No. 5, May 1972, pp. 2196-2203.

The results are shown below:

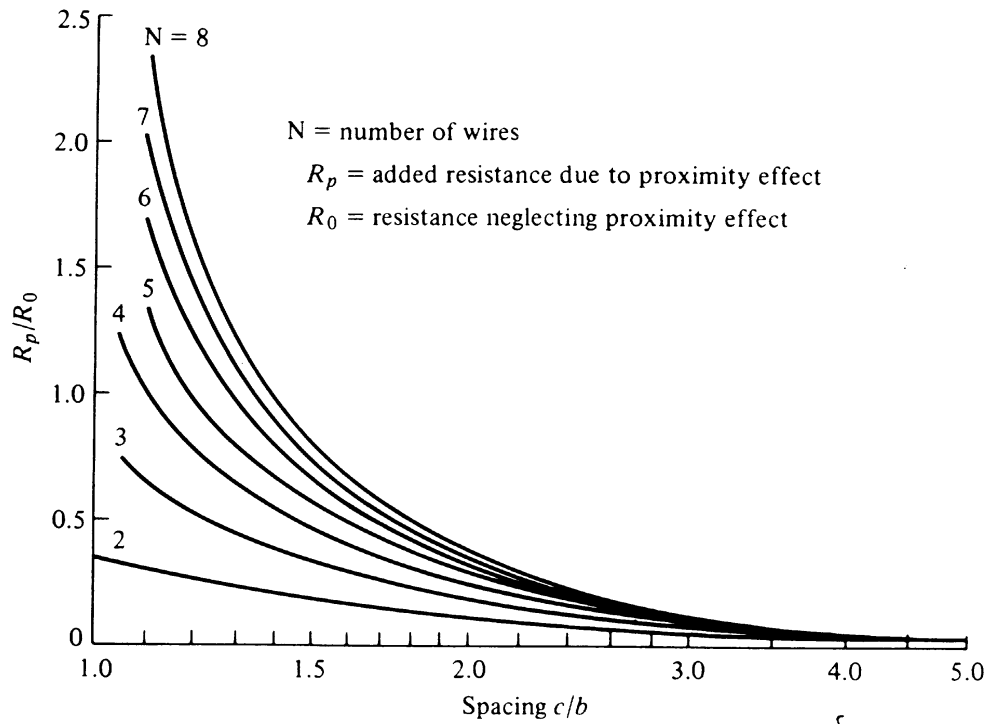

### (b) Loop inductance

The inductance of a single circular loop of radius  $a$  made of wire of radius  $b$  is

$$L_{A_1} = \mu a \left[ \ln \left( \frac{8a}{b} \right) - 2 \right] \quad (11.33)$$

The inductance of a square loop with sides  $a$  and wire radius  $b$  is calculated as:

$$L_{A_1}^{sq} = 2\mu \frac{a}{\pi} \left[ \ln \left( \frac{a}{b} \right) - 0.774 \right] \quad (11.34)$$

The inductance of the wire itself is very small and is often neglected. It can be shown that the self-inductance of a straight wire of length  $l$  is:

$$L_i = \frac{\mu}{4} \cdot l \quad (11.35)$$

For a single loop,  $l = 2\pi a$ .

(c) Resonance capacitor

The susceptance of the capacitor  $B_r$  must be chosen to eliminate the susceptance of the loop. The equivalent admittance of the loop is:

$$Y_{in} = \frac{1}{Z_{in}} = \frac{1}{R_{in} + jX_{in}} \quad (11.36)$$

where

$$\begin{aligned} R_{in} &= R_r + R_l \\ X_{in} &= j\omega(L_A + L_i). \end{aligned}$$

The following transformation holds:

$$Y_{in} = G_{in} + jB_{in} \quad (11.37)$$

where

$$\left| \begin{aligned} G_{in} &= \frac{R_{in}}{R_{in}^2 + X_{in}^2} \\ B_{in} &= \frac{-X_{in}}{R_{in}^2 + X_{in}^2} \end{aligned} \right. \quad (11.38)$$

The susceptance of the capacitor is

$$B_r = \omega C_r \quad (11.39)$$

For resonance to occur at  $f_0 = \omega_0 / (2\pi)$ , the condition

$$B_r = -B_{in} \quad (11.40)$$

must be fulfilled. Therefore,

$$2\pi f_0 C_r = \frac{X_{in}}{R_{in}^2 + X_{in}^2} \quad (11.41)$$



$$\Rightarrow C_r = \frac{1}{2\pi f} \frac{X_{in}}{(R_{in}^2 + X_{in}^2)} \quad (11.42)$$

Under resonance, the input impedance  $Z'_{in}$  becomes:

$$Z'_{in} = R'_{in} = \frac{1}{G'_{in}} = \frac{1}{G_{in}} = \frac{R_{in}^2 + X_{in}^2}{R_{in}} \quad (11.43)$$

$$\Rightarrow Z'_{in} = R_{in} + \frac{X_{in}^2}{R_{in}}, \quad \Omega \quad (11.44)$$

## 5. The small loop as a receiving antenna

The small loop antennas have the following features:

- 1) high radiation resistance provided multi-turn ferrite-core constructions are used;
- 2) high losses, therefore, low radiation efficiency;
- 3) simple construction, small size and weight.

Small loop antennas are never used as transmitting antennas due to their low efficiency  $e_{cd}$ . However, they are very much preferred as receiving antennas in AM radio-receivers because of their high signal-to-noise ratio (they can be easily tuned to form a very high-Q resonant circuit), their small size and low cost.

Loops are constructed as magnetic field probes to measure magnetic flux densities. At higher frequencies (UHF and microwave), loops are used to measure the EM field intensity. In this case, no ferrite rods are used.

It is obvious that the loop has to be oriented properly to optimize the reception. The optimal reception depends not only on the direction from which the incident wave approaches but also on the field polarization.

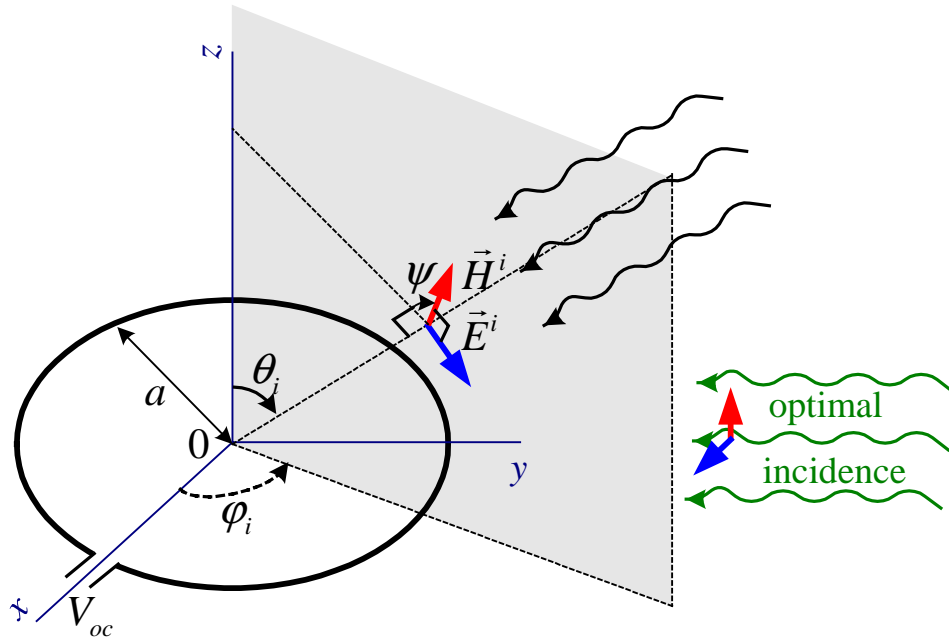

The open-circuit voltage at the loop terminals is induced by the time-varying magnetic flux through the loop.

$$V_{oc} = j\omega\Psi_m = j\omega\vec{B} \cdot \vec{s} = j\omega\mu H_z \cdot \pi a^2 \quad (11.45)$$

$$H_z = H^i \cos\psi \sin\theta_i \quad (11.46)$$

Here,

$\Psi_m$  is the magnetic flux, Wb;

$(\theta_i, \varphi_i)$  are the angles specifying the direction of incidence;

$\psi$  is the angle between the  $\vec{H}^i$  vector and the plane of incidence.

Finally, the open-circuit voltage can be expressed as:

$$V_{oc} = j\omega\mu S H^i \cos\psi \sin\theta_i = j\beta S E^i \cos\psi \sin\theta_i \quad (11.47)$$

Here,  $S = \pi a^2$  denotes the area of the loop, and  $\beta = \omega\sqrt{\mu\epsilon}$  is the phase constant.  $V_{oc}$  is maximum for  $\theta_i = 90^\circ$  and  $\psi = 0^\circ$ .

## 6. Ferrite loops

The radiation resistance and radiation efficiency can be raised by inserting a ferrite core, which has high magnetic permeability in the operating frequency band. Large magnetic permeability  $\mu = \mu_0 \mu_r$  means large magnetic flux  $\Psi_m$ , and therefore large induced voltage  $V_{oc}$ . The radiation resistance of a small loop was already derived in (11.10) to include the number of turns, and it was shown that it increases as  $\sim N^2$ . Now the magnetic properties of the loop will be included in the expression for  $R_r$ .

The magnetic properties of a ferrite core depend not only on the relative magnetic permeability  $\mu_r$  of the material it is made of but also on its geometry. The increase in the magnetic flux is then more realistically represented by the *effective relative permeability* (*effective magnetic constant*)  $\mu_{r_{eff}}$ . We shall show that the radiation resistance of a ferrite-core loop is  $\mu_{r_{eff}}^2$  times larger than the radiation resistance of the air-core loop of the same geometry. When we calculated the far fields of a small loop, we made use of the equivalence between an electric current loop and a magnetic current element:

$$j\omega\mu(IA) = I_m l \quad (11.48)$$

From (11.48) it is obvious that the equivalent magnetic current is proportional to  $\mu$ . Then, it should be reminded that the field magnitudes are also proportional to  $I_m$ , and therefore they are proportional to  $\mu$ , too. This means that the radiated power  $\Pi_{rad}$  is proportional to  $\mu^2$ , and therefore the radiation resistance increases as  $\sim \mu_{r_{eff}}^2$ .

Finally, one can express in most general form the radiation resistance as:

$$R_r = \eta_0 \frac{8}{3} \pi^3 \left( N \mu_{r_{eff}} \frac{A}{\lambda^2} \right)^2 \quad (11.49)$$

Here,  $A = \pi a^2$  is the loop area, and  $\eta_0 = \sqrt{\mu_0 / \epsilon_0}$  is the intrinsic impedance of vacuum.

Some notes will be made with regard to the properties of ferrite cores.

- The effective magnetic constant of a ferrite core is always less than the magnetic constant of the ferromagnetic material it is made of, i.e.  $\mu_{r_{eff}} < \mu_r$ . Toroidal cores have the highest  $\mu_{r_{eff}}$ , and ferrite-stick cores have the lowest  $\mu_{r_{eff}}$ .
- The effective magnetic constant is frequency dependent. One has to be careful when picking the right core for the application at hand.
- The magnetic losses of ferromagnetic materials increase with frequency. At very high (microwave) frequencies, the magnetic losses are not negligible. They have to be calculated and represented in the equivalent circuit of the antenna as a shunt conductance  $G_m$ .