

Feel Yourself a Student!

Dear friends, I would like to give to you an interesting and reliable antenna theory. Hours searching in the web gave me lots theoretical information about antennas. Really, at first I did not know what information to chose for ANTENTOP. Finally, I stopped on lectures "Modern Antennas in Wireless Telecommunications" written by Prof. Natalia K. Nikolova from McMaster University, Hamilton, Canada.

You ask me: Why?

Well, I have read many textbooks on Antennas, both, as in Russian as in English. So, I have the possibility to compare different textbook, and I think, that the lectures give knowledge in antenna field in great way. Here first lecture "Introduction into Antenna Study" is here. Next issues of ANTENTOP will contain some other lectures.

So, feel yourself a student! Go to Antenna Studies!

I.G.

My Friends, the above placed Intro was given at ANTENTOP- 01- 2003 to Antennas Lectures.

Now I know, that the Lecture is one of popular topics of ANTENTOP. Every of Antenna Lectures was downloaded more than 1000 times!

Now I want to present to you one more very interesting Lecture - it is **Fundamental Antenna Parameters**. I believe, you cannot find such info anywhere for free! It is very interesting and very useful info for every ham, for every radio- engineer.

So, feel yourself a student! Go to Antenna Studies!

I.G.

McMaster University Hall

Prof. Natalia K. Nikolova



LECTURE 4: Fundamental Antenna Parameters

(Radiation pattern. Pattern beamwidths. Radiation intensity. Directivity. Gain. Antenna efficiency and radiation efficiency. Frequency bandwidth. Input impedance and radiation resistance. Antenna equivalent area.

by Prof. Natalia K. Nikolova

LECTURE 4: Fundamental Antenna Parameters

(Radiation pattern. Pattern beamwidths. Radiation intensity. Directivity. Gain. Antenna efficiency and radiation efficiency. Frequency bandwidth. Input impedance and radiation resistance. Antenna equivalent area. Relationship between directivity and area.)

The antenna parameters describe the antenna performance with respect to space distribution of the radiated energy, power efficiency, matching to the feed circuitry, etc. Many of these parameters are interrelated. There are several parameters not described here, such as *antenna temperature and noise characteristics*. They will be discussed later in conjunction with radiowave propagation and system performance.

1. Radiation pattern

The *radiation pattern* (RP) (or *antenna pattern*) is the representation of the radiation properties of the antenna as a function of space coordinates.

The RP is measured in the far-field region, where the spatial (angular) distribution of the radiated power does not depend on the distance. One can measure and plot the field intensity, e.g. $\sim |\vec{E}(\theta, \varphi)|$, or the received power

$$\sim \frac{|\vec{E}(\theta, \varphi)|^2}{\eta} = \eta |\vec{H}(\theta, \varphi)|^2$$

The trace of the spatial variation of the received/radiated power at a constant radius from the antenna is called the *power pattern*.

The trace of the spatial variation of the electric (magnetic) field at a constant radius from the antenna is called the *amplitude field pattern*.

Usually, the pattern describes the *normalized* field (power) values with respect to the maximum value.

Note: The power pattern and the amplitude field pattern are the same when computed and plotted in dB.

The pattern can be a 3-D plot (both θ and φ vary), or a 2-D plot. A 2-D plot is obtained as an intersection of the 3-D one with a given plane, usually a $\theta = \text{const.}$ plane or a $\varphi = \text{const.}$ plane that must contain the pattern's maximum.

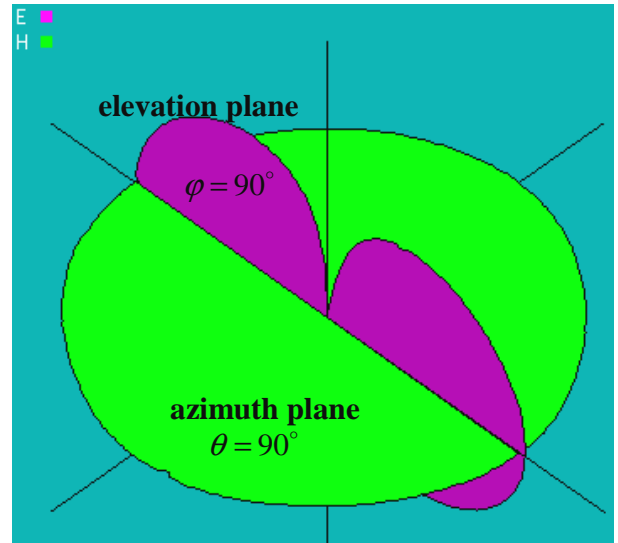
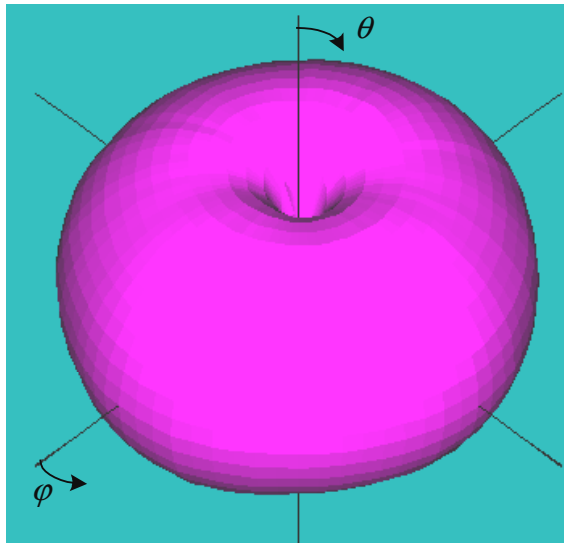

Plotting the pattern: the trace of the pattern is obtained by setting the length of the radius-vector $|\vec{r}(\theta, \varphi)|$ proportional to the strength of the field $|\vec{E}(\theta, \varphi)|$ (in the case of an amplitude field pattern) or proportional to the power density $|\vec{E}(\theta, \varphi)|^2$ (in the case of a power pattern).

Elevation plane: $\varphi = \text{const}$

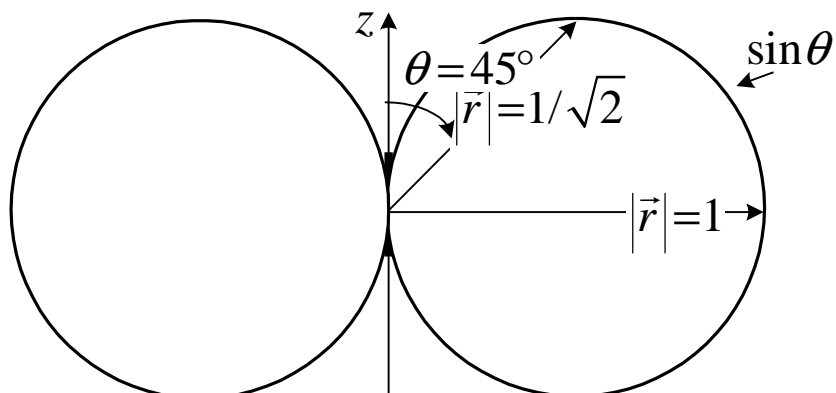

Some concepts related to the pattern terminology

- a) **Isotropic pattern** is the pattern of an antenna having equal radiation in all directions. This is an ideal (not physically achievable) concept. However, it is used to define other antenna parameters. It is represented simply by a sphere whose center coincides with the location of the isotropic radiator.
- b) **Directional antenna** is an antenna, which radiates (receives) much more efficiently in some directions than in others. Usually, this term is applied to antennas whose directivity is much higher than that of a half-wavelength dipole.
- c) **Omnidirectional antenna** is an antenna, which has a non-directional pattern in a given plane, and a directional pattern in any orthogonal plane (e.g. single-wire antennas).

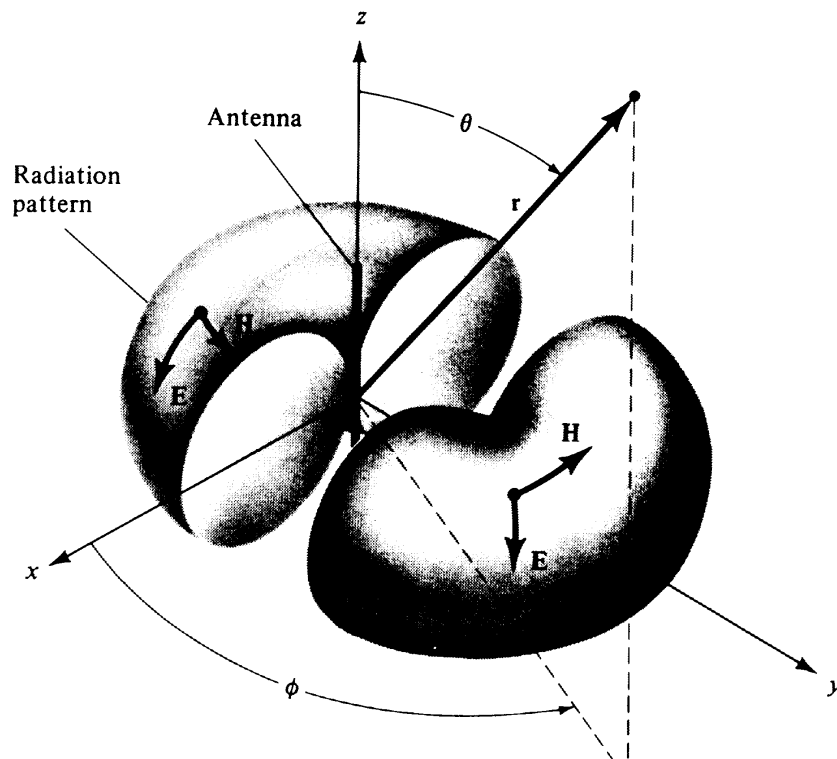

d) **Principal patterns** are the 2-D patterns of linearly polarized antennas, measured in the ***E-plane*** (a plane parallel to the \vec{E} vector and containing the direction of maximum radiation) and in the ***H-plane*** (a plane parallel to the \vec{H} vector, orthogonal to the *E-plane*, and containing the direction of maximum radiation).

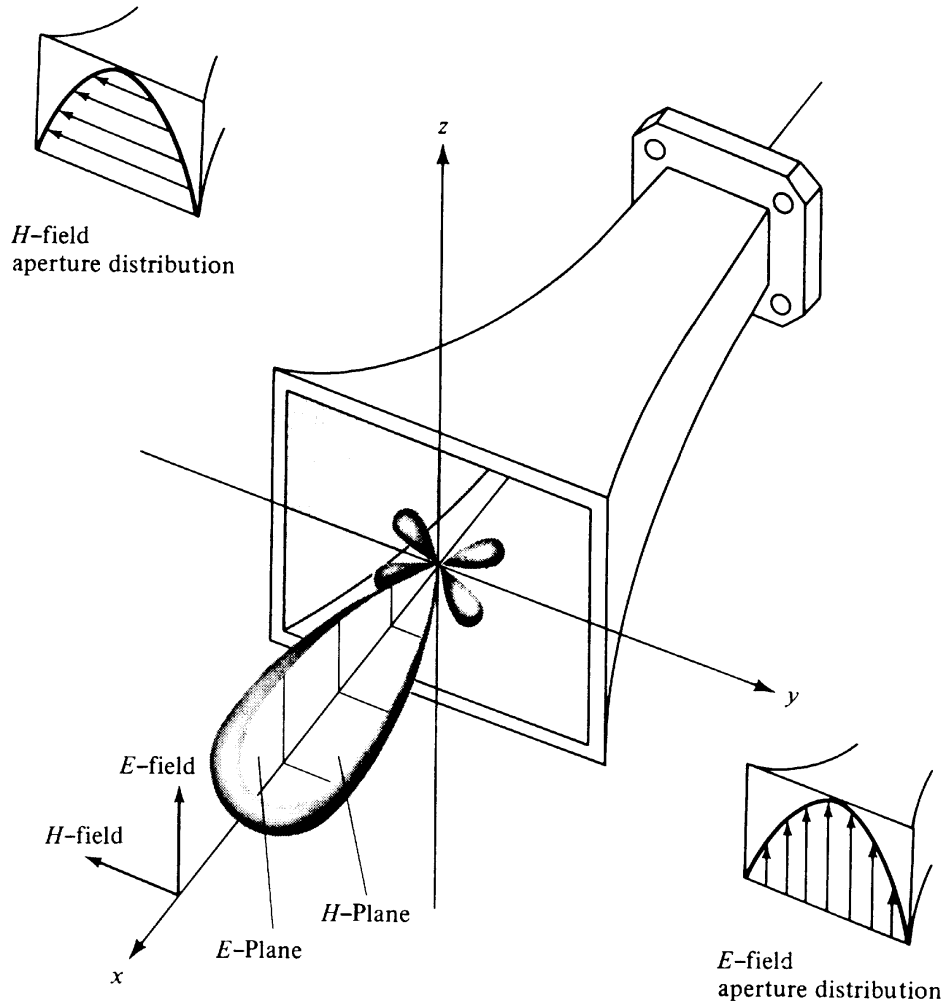

e) **Pattern lobe** is a portion of the RP whose local radiation intensity maximum is relatively weak.

Lobes are classified as: major, minor, side lobes, back lobes.

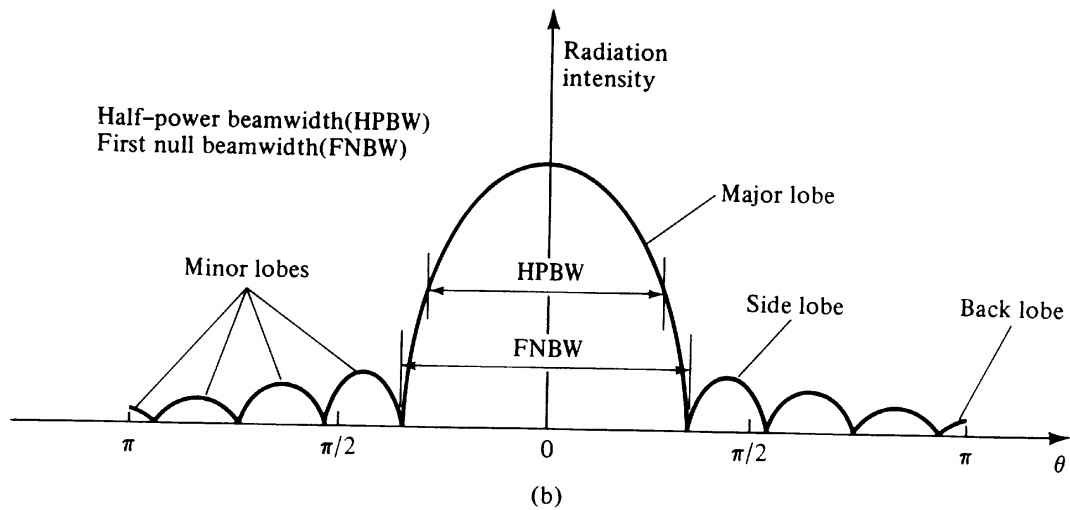
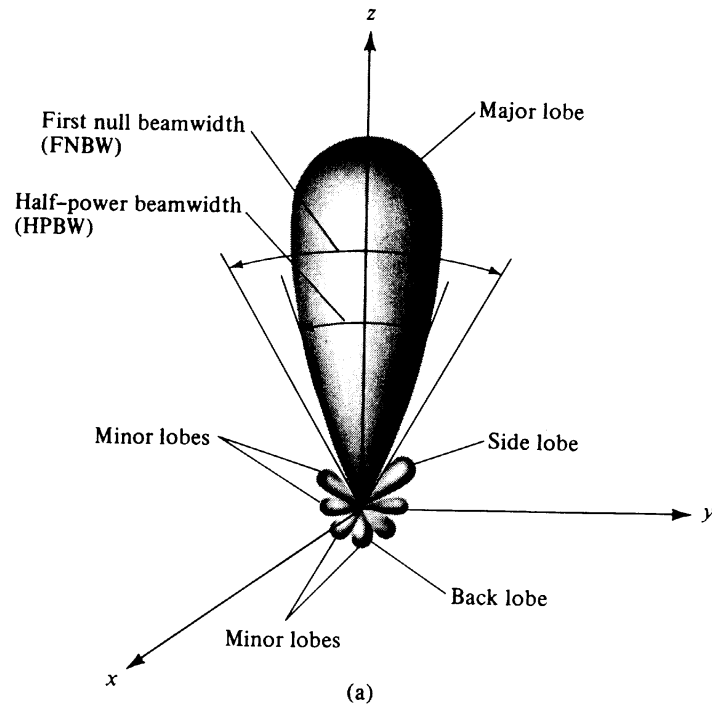

2. Pattern beamwidth

Half-power beamwidth (HPBW) is the angle between two vectors, originating at the pattern's origin and passing through these points of the major lobe where the radiation intensity is half its maximum.

First-null beamwidth (FNBW) is the angle between two vectors, originating at the pattern's origin and tangent to the main beam at its base. It very often approximately true that $FNBW \approx 2 \cdot HPBW$.

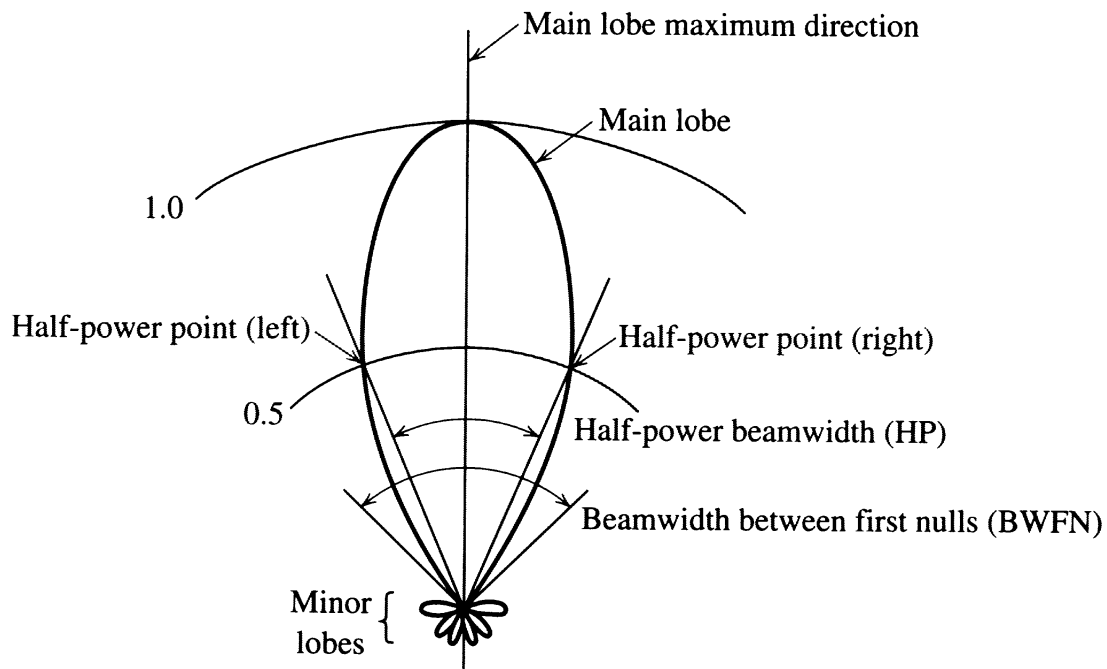

The HPBW is the best parameter to describe the antenna resolution properties. In radar technology as well as in radioastronomy, the antenna resolution capability is of primary importance.

3. Radiation intensity

Radiation intensity in a given direction is the power per unit solid angle radiated in this direction by the antenna.

a) Solid angle

One **steradian** (*st*) is the solid angle with its vertex at the center of a sphere of radius r , which is subtended by a spherical surface area equal to

that of a square with each side of length r . In a closed sphere, there are (4π) steradians.

$$\Omega = \frac{S_{\Omega}}{r^2}, \text{ sr} \quad (4.1)$$

Note: The above definition is analogous to the definition of a 2-D angle in radians, $\omega = l_{\omega} / \rho$, where l_{ω} is the length of the arc segment supported by the angle ω in a circle of radius ρ .

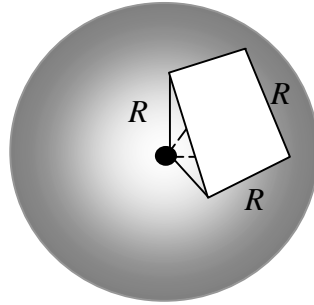

The infinitesimal area ds on a surface of a sphere of radius R in spherical coordinates is:

$$ds = r^2 \sin \theta d\theta d\varphi, \text{ m}^2 \quad (4.2)$$

Therefore,

$$d\Omega = \sin \theta d\theta d\varphi, \text{ sr} \quad (4.3)$$

b) Radiation intensity U

$$U = \frac{d\Pi_{rad}}{d\Omega}, \text{ W/sr} \quad (4.4)$$

A useful expression, equivalent to (4.4) is given below:

$$\Pi_{rad} = \oint\limits_{4\pi} U d\Omega, \text{ W} \quad (4.5)$$

From now on, we shall denote the radiated power simply by Π . There is a direct relation between the radiation intensity U and the radiation power density P (that is the Poynting vector magnitude of the far field). Since

$$P = \frac{d\Pi}{ds}, \text{ W/m}^2 \quad (4.6)$$

then:

$$U = r^2 \cdot P \quad (4.7)$$

It was already shown that the power density of the far field depends on the distance from the source r as $1/r^2$, since the far field magnitudes depend on r as $1/r$. Thus, the radiation intensity U depends only on the direction (θ, φ) but not on the distance r .

The power pattern is a trace of the function $|U(\theta, \varphi)|$ usually normalized to its maximum value. The normalized pattern will be denoted as $\bar{U}(\theta, \varphi)$.

In the far-field zone, the radial field components vanish, and the remaining transverse components of the electric and the magnetic far fields are in phase and have magnitudes related by:

$$|\vec{E}| = \eta |\vec{H}| \quad (4.8)$$

That is why the far-field Poynting vector has only a radial component and it is a real number corresponding to the radiation density:

$$P_{rad} = P = \frac{1}{2} \eta |\vec{H}|^2 = \frac{1}{2} \frac{|\vec{E}|^2}{\eta} \quad (4.9)$$

Then, one obtains for the radiation intensity in terms of the electric field:

$$U(\theta, \varphi) = \frac{r^2}{2\eta} |\vec{E}|^2 \quad (4.10)$$

Equation (4.10) leads to a useful relation between the power pattern and the amplitude field pattern:

$$U(\theta, \varphi) = \frac{r^2}{2\eta} |E_\theta^2(r, \theta, \varphi) + E_\varphi^2(r, \theta, \varphi)| = \frac{1}{2\eta} |E_{\theta_p}^2(\theta, \varphi) + E_{\varphi_p}^2(\theta, \varphi)| \quad (4.11)$$

Here, $E_{\theta_p}(\theta, \varphi)$ and $E_{\varphi_p}(\theta, \varphi)$ denote the far-zone field patterns.

Examples:

1) Radiation intensity and pattern of an isotropic radiator

$$\begin{aligned} P(r, \theta, \varphi) &= \frac{\Pi}{4\pi r^2} \\ U(\theta, \varphi) &= r^2 \cdot P = \frac{\Pi}{4\pi} = \text{const.} \\ \Rightarrow \bar{U}(\theta, \varphi) &= 1 \end{aligned}$$

The normalized pattern of an isotropic radiator is simply a sphere of a unit radius.

2) Radiation intensity and pattern of an infinitesimal dipole

From equation (3.33), Lecture 3, the far-field term of the electric field is:

$$E_{\theta} = j\eta \frac{\beta \cdot (I\Delta l) \cdot e^{-j\beta r}}{4\pi r} \cdot \sin \theta \Rightarrow \bar{E}(\theta, \varphi) = \sin \theta$$

$$U = \frac{r^2}{2\eta} \cdot |\vec{E}|^2 = \eta \frac{\beta^2 \cdot (I\Delta l)^2}{32\pi^2} \cdot \sin^2 \theta$$

$$\Rightarrow \underline{\bar{U}(\theta, \varphi) = \sin^2 \theta}$$

4. Directivity

4.1. Definitions and examples

Directivity of an antenna in a given direction is the ratio of the radiation intensity in this direction and the radiation intensity averaged over all directions. The radiation intensity averaged over all directions is equal to the total power radiated by the antenna divided by 4π . If a direction is not specified, then the direction of maximum radiation is implied.

It can be also defined as the ratio of the radiation intensity (RI) of the antenna in a given direction and the RI of an isotropic radiator fed by the same amount of power.

$$D(\theta, \varphi) = \frac{U(\theta, \varphi)}{U_{av}} = 4\pi \frac{U(\theta, \varphi)}{\Pi}, \quad (4.12)$$

and

$$D_{\max} = D_0 = 4\pi \frac{U_{\max}}{\Pi}$$

The directivity is a dimensionless quantity. The maximum directivity is always ≥ 1 .

Examples:

1) directivity of an isotropic source

$$\begin{aligned}U(\theta, \varphi) &= U_0 = \text{const.} \\ \Rightarrow \Pi &= 4\pi U_0 \\ \Rightarrow D(\theta, \varphi) &= 4\pi \frac{U(\theta, \varphi)}{\Pi} = 1 \\ \Rightarrow \underline{D_0} &= \underline{1}\end{aligned}$$

2) directivity of an infinitesimal dipole

$$\begin{aligned}U(\theta, \varphi) &= \eta \frac{\beta^2 \cdot (I\Delta l)^2}{32\pi^2} \cdot \sin^2 \theta \\ \Rightarrow \bar{U}(\theta, \varphi) &= \sin^2 \theta; \quad U(\theta, \varphi) = M \cdot \bar{U}(\theta, \varphi)\end{aligned}$$

As shown in (4.5)

$$\begin{aligned}\Pi &= \oiint U d\Omega = M \cdot \int_0^\pi \int_0^{2\pi} \sin^2 \theta \cdot \sin \theta d\theta d\varphi \\ \Pi &= M \cdot \frac{8\pi}{3} \\ D(\theta, \varphi) &= 4\pi \frac{U(\theta, \varphi)}{\Pi} = \frac{3}{2} \sin^2 \theta \\ \Rightarrow \underline{D_0} &= \underline{1.5}\end{aligned}$$

Exercise: Calculate the maximum directivity of an antenna with a radiation intensity $U = M \sin \theta$. (Answer: $D_0 = 4/\pi \approx 1.27$)

Partial directivity of an antenna is specified for a given polarization of the field. It is defined as that part of the radiation intensity, which corresponds to a given polarization, divided by the total radiation intensity averaged over all directions.

The total directivity is the sum of the partial directivities for any two orthogonal polarizations:

$$D_0 = D_\theta + D_\varphi, \quad (4.13)$$

where:

$$D_\theta = 4\pi \frac{U_\theta}{\Pi_\theta + \Pi_\varphi}$$

$$D_\varphi = 4\pi \frac{U_\varphi}{\Pi_\theta + \Pi_\varphi}.$$

4.2. Directivity in terms of relative radiation intensity $\bar{U}(\theta, \varphi)$

$$U(\theta, \varphi) = M \cdot \bar{U}(\theta, \varphi) \quad (4.14)$$

$$\Pi = \oint\oint_{4\pi} U d\Omega = M \cdot \int_0^\pi \int_0^{2\pi} \bar{U}(\theta, \varphi) \sin\theta d\theta d\varphi \quad (4.15)$$

$$D(\theta, \varphi) = 4\pi \frac{\bar{U}(\theta, \varphi)}{\int_0^\pi \int_0^{2\pi} \bar{U}(\theta, \varphi) \sin\theta d\theta d\varphi} \quad (4.16)$$

$$D_0 = 4\pi \frac{1}{\int_0^\pi \int_0^{2\pi} \bar{U}(\theta, \varphi) \sin\theta d\theta d\varphi} \quad (4.17)$$

4.3. Beam solid angle Ω_A

The **beam solid angle** Ω_A of an antenna is the solid angle through which all the power of the antenna would flow, if its radiation intensity were constant and equal to the maximum radiation intensity U for all angles within Ω .

$$\Omega_A = \int_0^\pi \int_0^{2\pi} \bar{U}(\theta, \varphi) \sin\theta d\theta d\varphi \quad (4.18)$$

The relation between the maximum directivity and the beam solid angle is obvious:

$$D_0 = \frac{4\pi}{\Omega_A} \quad (4.19)$$

4.4. Approximate expressions for directivity

The complexity of the calculation of the antenna directivity D_0 depends on the power pattern $\bar{U}(\theta, \varphi)$, which has to be integrated over a spherical surface. In most practical cases, this function is not available in closed analytical form (e.g. it might be a data set). Even if it is available in closed analytical form, the integral in (4.17) may not have a closed analytical solution. In practice, simpler although not exact expressions are often used for approximate and fast calculations. These formulas are based on the two orthogonal-plane half power beam widths (HPBW) of the pattern.

a) Kraus' formula

For antennas with narrow major lobe and with very negligible minor lobes, the beam solid angle Ω_A is approximately equal to the product of the HPBWs in two orthogonal planes:

$$\Omega_A = \Theta_1 \Theta_2, \quad (4.20)$$

where the HPBW *angles are in radians*. Another variation of (4.20) is

$$D_0 \approx \frac{41000}{\Theta_1^\circ \Theta_2^\circ}, \quad (4.21)$$

where Θ_1° and Θ_2° *are in degrees*.

b) Formula of Tai and Pereira

$$D_0 \approx \frac{32 \ln 2}{\Theta_1^2 + \Theta_2^2} \quad (4.22)$$

The angles in (4.22) are in radians.

For details see: C. Tai and C. Pereira, "An approximate formula for calculating the directivity of an antenna," *IEEE Trans. on AP*, vol. AP-24, No. 2, March 1976, pp. 235-236.

5. Antenna gain

The gain G of an antenna is the ratio of the radiation intensity U in a given direction and the radiation intensity that would be obtained, if the power fed to the antenna were radiated isotropically.

$$G(\theta, \varphi) = 4\pi \frac{U(\theta, \varphi)}{P_{in}} \quad (4.23)$$

The gain is a dimensionless quantity, which is very similar to the directivity D . When the antenna has no losses, i.e. when $P_{in} = \Pi$, then $G(\theta, \varphi) = D(\theta, \varphi)$.

Thus, the gain of the antenna takes into account the losses in the antenna system. It is calculated via the *input power* P_{in} , which is a measurable quantity, unlike the directivity, which is calculated via the radiated power Π .

There are many factors that can worsen the transfer of energy from the transmitter to the antenna (or from the antenna to the receiver):

- Mismatch losses
- Losses in the transmission line
- Losses in the antenna: dielectric losses, conduction losses, polarization losses

The power radiated by the antenna is always less than the power fed to the antenna system, $\Pi \leq P_{in}$, unless the antenna has integrated active devices. That is why usually $G \leq D$.

! According to IEEE Standards, the gain does not include losses arising from impedance mismatch and from polarization mismatch.

Therefore, the gain takes into account only the dielectric and conduction losses of the antenna system itself.

The radiated power is related to the input power through a coefficient called the *radiation efficiency*:

$$\Pi = e \cdot P_{in}, \quad e \leq 1 \quad (4.24)$$

$$\Rightarrow G(\theta, \varphi) = e \cdot D(\theta, \varphi) \quad (4.25)$$

Partial gains with respect to a given field polarization are defined in the same way as it is done with the antenna partial directivities, see equation (4.13).

6. Antenna efficiency

The total efficiency of the antenna e_t is used to estimate the total loss of energy at the input terminals of the antenna and within the antenna structure. It includes all mismatch losses and the dielectric/conduction losses (described by the *radiation efficiency* e as defined by the IEEE Standards):

$$e_t = e_p e_r \underbrace{e_c e_d}_e = e_p e_r \cdot e \quad (4.26)$$

Here: e_r is the reflection (impedance mismatch) efficiency,
 e_p is the polarization mismatch efficiency,
 e_c is the conduction efficiency,
 e_d is the dielectric efficiency.

The reflection efficiency can be calculated through the reflection coefficient Γ at the antenna input:

$$e_r = 1 - |\Gamma|^2 \quad (4.27)$$

Γ can be either measured or calculated, provided the antenna impedance is known:

$$\Gamma = \frac{Z_{in} - Z_c}{Z_{in} + Z_c} \quad (4.28)$$

Z_{in} is the antenna input impedance, and Z_c is the characteristic impedance of the feed line. If there are no polarization losses, then the total efficiency is related to the radiation efficiency as:

$$e_t = e \cdot (1 - |\Gamma|^2) \quad (4.29)$$

7. Beam efficiency

The *beam efficiency* is the ratio of the power radiated in a cone of angle $2\Theta_1$ and the total radiated power. The angle $2\Theta_1$ can be generally any angle, but usually this is the first-null beam width.

$$BE = \frac{\int_0^{2\pi} \int_0^{\Theta_1} U(\theta, \varphi) \sin \theta d\theta d\varphi}{\int_0^{2\pi} \int_0^{\pi} U(\theta, \varphi) \sin \theta d\theta d\varphi} \quad (4.30)$$

If the antenna has its major lobe directed along the z -axis ($\theta = 0$), formula (4.30) defines the BE. If θ_1 is the angle where the first null (or minimum) occurs in two orthogonal planes, then the BE will show what part of the total radiated power is channeled through the main beam.

Very high beam-efficiency antennas are needed in radars, radiometry and astronomy.

8. Frequency bandwidth (FBW)

This is the range of frequencies, within which the antenna characteristics conform to a specified standard.

Antenna characteristics, which should conform to certain requirements, might be: input impedance, radiation pattern, beamwidth, polarization, side-lobe level, gain, beam direction and width, radiation efficiency. Often, separate bandwidths are introduced: impedance bandwidth, pattern bandwidth, etc.

The FBW of broadband antennas is expressed as the ratio of the upper to the lower frequencies, where the antenna performance is acceptable:

$$\text{FBW} = \frac{f_{\max}}{f_{\min}} \quad (4.31)$$

Recently, broadband antennas with FBW as large as 40:1 have been designed. Such antennas are referred to as *frequency independent antennas*.

For narrowband antennas, the FBW is expressed as a percentage of the frequency difference over the center frequency:

$$\text{FBW} = \frac{f_{\max} - f_{\min}}{f_0} \cdot 100\% \quad (4.32)$$

Usually, $f_0 = (f_{\max} + f_{\min})/2$, or $f_0 = \sqrt{f_{\max} f_{\min}}$.

9. Input impedance

$$Z_A = R_A + jX_A, \quad (4.33)$$

where:

R_A is the antenna resistance

X_A is the antenna reactance.

Generally, the antenna resistance has two terms:

$$R_A = R_r + R_l, \quad (4.34)$$

where:

R_r is the radiation resistance

R_l is the loss resistance.

The antenna impedance is related to the radiated power Π , the dissipated power P_l , and the stored reactive energy, in the following way:

$$Z_A = \frac{P_r + P_d + 2j\omega(W_m - W_e)}{\frac{1}{2}I_0 I_0^*} \quad (4.35)$$

Here, I_0 is the current at the antenna terminals; W_m is the average magnetic energy and W_e is the average electric energy stored in the near-field region. When the stored magnetic and electric energy are equal, a condition of resonance occurs, and the reactive part of Z_A vanishes. For a thin dipole antenna this occurs when the antenna length is close to a multiple of a half wavelength.

9.1. Radiation resistance.

The radiation resistance relates the radiated power to the voltage (or current) at the antenna terminals. For example, in the Thevenin equivalent, the following holds:

$$R_r = \frac{2\Pi}{|I|^2}, \quad \Omega \quad (4.36)$$

Example: Find the radiation resistance of an infinitesimal dipole in terms of the ratio $(\Delta l / \lambda)$.

We have already derived the radiated power of an infinitesimal dipole in (3.14), Lecture 3, as:

$$\Pi^{id} = \eta \frac{\pi}{3} \left(\frac{I \Delta l}{\lambda} \right)^2 \quad (4.37)$$

$$R_r^{id} = \eta \frac{2\pi}{3} \left(\frac{\Delta l}{\lambda} \right)^2 \quad (4.38)$$

9.2. Equivalent circuits of the transmitting antenna

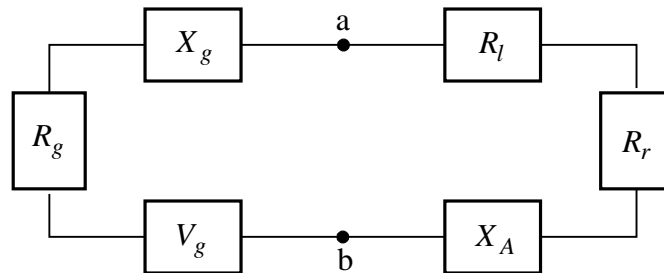
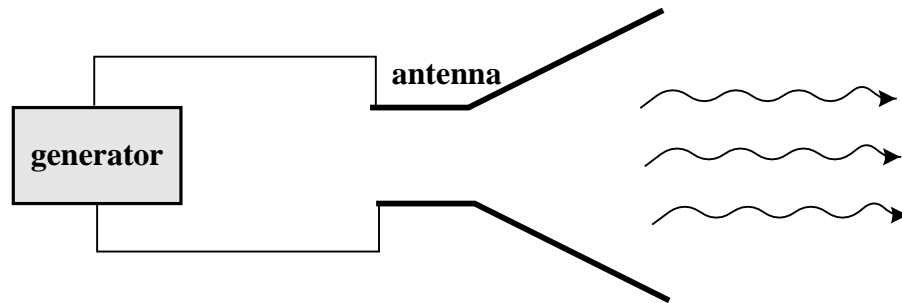

(a) Thevenin equivalent

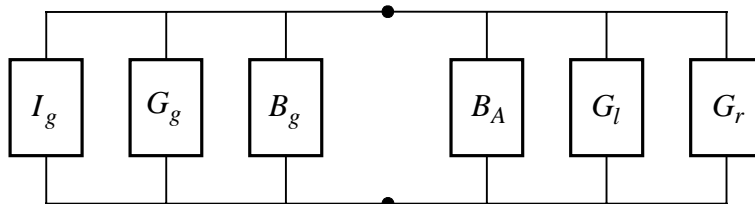

(b) Norton equivalent

In the above model, it is assumed that the generator is connected to the antenna directly. If there is a transmission line between the generator and the antenna, which is usually the case, then $Z_g = R_g + jX_g$ will represent the equivalent impedance of the generator transferred to the input terminals of the antenna. Transmission lines themselves often have significant losses.

The maximum power delivered to the antenna is achieved when conjugate matching of impedances is in place:

$$\begin{cases} R_A = R_l + R_r = R_g \\ X_A = -X_g \end{cases} \quad (4.39)$$

Using circuit theory, one can easily derive the following formulas:

a) power delivered to the antenna

$$P_A = \frac{|V_g|^2}{8(R_r + R_l)} \quad (4.40)$$

b) power dissipated as heat in the generator

$$P_g = P_A = \frac{|V_g|^2}{8R_g} = \frac{|V_g|^2}{8(R_r + R_l)} \quad (4.41)$$

c) radiated power

$$\Pi = P_r = \frac{|V_g|^2}{8} \frac{R_r}{(R_r + R_l)^2} \quad (4.42)$$

d) power dissipated as heat in the antenna

$$P_l = \frac{|V_g|^2}{8} \frac{R_l}{(R_r + R_l)^2} \quad (4.43)$$

9.3. Equivalent circuits of the receiving antenna

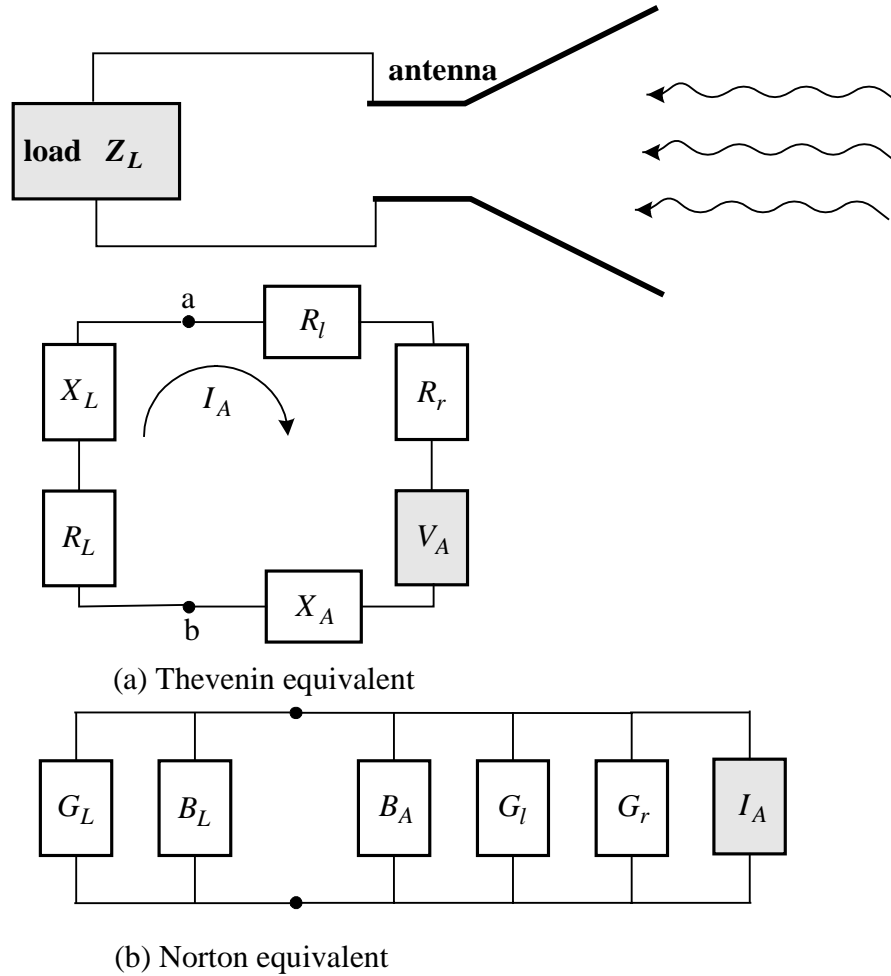

The incident wave induces voltage V_A at the antenna terminals (measured when the antenna is open circuited). Conjugate impedance matching is required between the antenna and the load (the receiver) to achieve maximum power delivery:

$$\begin{cases} R_L = R_A = R_l + R_r \\ X_L = -X_A \end{cases} \quad (4.44)$$

For the case of conjugate matching, the following power expressions are found:

a) power delivered to the load

$$P_L = \frac{|V_A|^2}{8R_L} = \frac{|V_A|^2}{8R_A} \quad (4.45)$$

b) power dissipated as heat in the antenna

$$P_l = \frac{|V_A|^2}{8} \frac{R_l}{R_A^2} \quad (4.46)$$

c) scattered (re-radiated) power

$$P_r = \frac{|V_A|^2}{8} \frac{R_r}{R_A^2} \quad (4.47)$$

d) total captured power

$$P_c = \frac{|V_A|^2}{4(R_r + R_l)} = \frac{|V_A|^2}{4R_A} \quad (4.48)$$

When conjugate matching is achieved, half of the captured power P_c is delivered to the load (the receiver) and half is dissipated by the antenna (antenna losses). The antenna losses are heat dissipation P_l and reradiated (scattered) power P_r . When the antenna is lossless, only half of the power is delivered to the load (in the case of conjugate matching), the other half being scattered back into space.

! The antenna input impedance is frequency dependent. Thus, it is matched to its load in a certain frequency band. It can be influenced by the proximity of objects, too.

9.4. The radiation efficiency and the antenna losses

The radiation efficiency e takes into account the conductor-dielectric (heat) losses of the antenna. It is the ratio of the power radiated by the antenna and the total power delivered to the antenna terminals (in transmitting mode). In terms of equivalent circuit parameters:

$$e = \frac{R_r}{R_r + R_l} \quad (4.49)$$

Some useful formulas to calculate conduction losses will be given below.

a) dc resistance

$$R_{dc} = \frac{1}{\sigma} \frac{l}{A}, \quad \Omega \quad (4.50)$$

σ - specific conductivity, S/m

l - conductor's length, m

A - conductor's cross-section, m²

b) high-frequency surface resistance

At high frequencies, the current is confined in a thin layer at the conductor's surface, the skin-effect layer. Its effective thickness, known as the skin-depth, is:

$$\delta = \frac{1}{\sqrt{\pi f \sigma \mu}}, \text{ m} \quad (4.51)$$

f – frequency, Hz

μ - magnetic permeability, H/m

The surface resistance R_s (Ω) is defined through the tangential electric field and the collinear *surface* current density:

$$E = R_s \cdot J_s \quad (4.52)$$

The surface currents are related to the current volume density J as $J_s = \delta \cdot J$.

Then, (4.52) can be written as:

$$E = R_s \delta \cdot J \quad (4.53)$$

Since $J = \sigma E$, it follows that $R_s = \frac{1}{\delta \sigma}$. Finally,

$$R_s = \sqrt{\frac{\pi f \mu}{\sigma}}, \quad \Omega \quad (4.54)$$

One can also find a relation between the high-frequency resistance of a conducting rod of length l and a perimeter P and its surface resistance:

$$R_{hf} = \frac{1}{\sigma} \frac{l}{A} = \frac{1}{\sigma} \frac{l}{\delta \cdot P} = R_s \frac{l}{P} \quad (4.55)$$

Here the area $A = \delta \cdot P$ is not the actual area of the conducting rod, but is the effective area through which the high-frequency current flows.

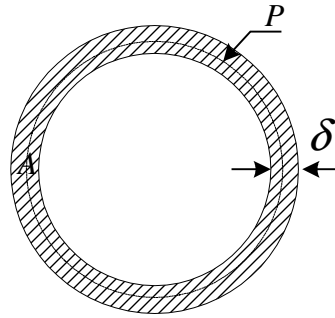

Example: A half-wavelength dipole is made out of copper ($\sigma = 5.7 \times 10^7$ S/m). Determine the radiation efficiency e , if the operating frequency is $f = 100$ MHz, the radius of the wire is $b = 3 \times 10^{-4} \cdot \lambda$, and the radiation resistance is $R_r = 73 \Omega$.

$$f = 10^8 \text{ Hz} \Rightarrow \lambda = \frac{c}{f} = 3 \text{ m} \Rightarrow l = \frac{\lambda}{2} = 1.5 \text{ m}$$

$$p = 2\pi b = 18\pi \times 10^{-4}, \text{ m}$$

If the current along the dipole were uniform, the high-frequency loss power would be uniformly distributed along the dipole, too. However, the current has a cosine distribution along the half-wavelength dipole:

$$I(z) = I_0 \cos\left(\frac{2\pi}{\lambda} z\right), \quad -\frac{\lambda}{4} \leq z \leq \frac{\lambda}{4}$$

Equation (4.55) can be now used to express the high-frequency loss resistance per wire element of infinitesimal length dz :

$$dR_{hf} = \frac{dz}{p} \sqrt{\frac{\pi f \mu_0}{\sigma}}$$

The high-frequency loss power per wire element of infinitesimal length dz is then obtained as:

$$dP_{hf} = \frac{1}{2} I_0^2 \cdot \frac{dz}{p} \sqrt{\frac{\pi f \mu_0}{\sigma}}$$

The total loss power is obtained by integrating along the whole dipole:

$$P_{hf} = \int_{-l/2}^{l/2} \frac{1}{2} \left[I_0 \cos\left(\frac{2\pi}{\lambda} z\right) \right]^2 \cdot \frac{1}{p} \sqrt{\frac{\pi f \mu_0}{\sigma}} dz$$

$$P_{hf} = \frac{I_0^2}{2} \cdot \frac{1}{p} \sqrt{\frac{\pi f \mu_0}{\sigma}} \cdot \int_{-l/2}^{l/2} \cos^2\left(\frac{2\pi}{\lambda} z\right) dz, \quad \lambda = 2 \cdot l$$

$$P_{hf} = \frac{I_0^2}{2} \cdot \underbrace{\left(\frac{l}{p} \sqrt{\frac{\pi f \mu_0}{\sigma}} \right)}_{R_{hf}} \cdot \int_{-l/2}^{l/2} \cos^2\left(\pi \frac{z}{l}\right) d\left(\frac{z}{l}\right)$$

$$P_{hf} = \frac{I_0^2}{2} \cdot R_{hf} \cdot \underbrace{\int_{-1/2}^{1/2} \cos^2(\pi\xi) d\xi}_{1/2}, \quad \xi = \frac{z}{l}$$

Since the loss resistance R_l is defined through the loss power as

$$P_{hf} = \frac{1}{2} R_l I_0^2,$$

one obtains that:

$$R_l = 0.5 \cdot R_{hf} = 0.5 \frac{l}{P} \sqrt{\frac{\pi f \mu_0}{\sigma}} = 0.349 \quad \Omega$$

The antenna efficiency is:

$$e = \frac{R_r}{R_r + R_l} = \frac{73}{73 + 0.349} = 0.9952$$

$$e_{[\text{dB}]} = 10 \log_{10} 0.9952 = -0.02$$

10. Effective area (aperture) A_e

The *effective antenna aperture* is the ratio of the available power at the terminals of the antenna to the power flux density of a plane wave incident upon the antenna, which is polarization matched to the antenna. If there is no specific direction chosen, the direction of maximum radiation intensity is implied.

$$A_e = \frac{P_A}{W_i}, \quad (4.56)$$

where:

A_e is the effective aperture, m^2

P_A is the power delivered from the antenna to the load, W

W_i is the power flux density (Poynting vector magnitude) of the incident wave, W/m^2

Using the Thevenin equivalent of a receiving antenna, one can show that equation (4.56) relates the antenna impedance and its effective aperture:

$$A_e = \frac{|I_A|^2 R_L / 2}{W_i} = \frac{|V_A|^2}{2W_i} \frac{R_L}{(R_r + R_l + R_L)^2 + (X_A + X_L)^2} \quad (4.57)$$

Under conditions of conjugate matching:

$$A_e = \frac{|V_A|^2}{8W_i} \frac{1}{\underbrace{(R_r + R_l)}_{R_A=R_L}} \quad (4.58)$$

For aperture-type antennas, the effective area is smaller than the physical aperture area. Aperture antennas with constant amplitude and phase distribution across the aperture have the maximum effective area, which is practically equal to the geometrical area. The effective aperture of wire antennas is much larger than the surface of the wire itself. Sometimes, the *aperture efficiency* of an antenna is estimated as the ratio of the effective antenna aperture and its physical area:

$$\epsilon_{ap} = \frac{A_e}{A_p} \quad (4.59)$$

Example: A uniform plane wave is incident upon a very short dipole. Find the effective area A_e assuming that the radiation resistance is $R = 80 \left(\frac{\pi l}{\lambda} \right)^2$, and that the field is linearly polarized along the axis of the dipole. Compare A_e with the physical surface of the wire, if $l = \lambda/50$ and $d = \lambda/300$, where d is the wire's diameter.

Since the dipole is very short, one can neglect the conduction losses. Wire antennas do not have dielectric losses. Therefore, $R_l = 0$. Under conjugate matching (which is implied unless specified otherwise)

$$A_e = \frac{|V_A|^2}{8W_i R_r}$$

The dipole is very short and one can assume that the \vec{E} -field intensity is the same along the whole wire. Then, the voltage created by the induced electromotive force of the incident wave is:

$$V_A = |\vec{E}| \cdot l$$

The Poynting vector has a magnitude of $W_i = \frac{|\vec{E}|^2}{2\eta}$. Then,

$$A_e = \frac{|\vec{E}|^2 \cdot l^2 \cdot 2\eta}{8 \cdot |\vec{E}|^2 \cdot R_r} = \frac{3\lambda^2}{8\pi} = 0.119 \cdot \lambda^2$$

The physical surface of the dipole is:

$$A_p = \frac{\pi d^2}{4} = \frac{\pi}{36} 10^{-4} \lambda^2 = 8.7 \times 10^{-6} \cdot \lambda^2$$

The aperture efficiency of this dipole would then be:

$$\varepsilon_{ap} = \frac{A_e}{A_p} = \frac{0.119}{8.7 \times 10^{-6}} = 1.37 \times 10^4$$

11. Relation between the directivity D_0 and the effective aperture A_e

The simplest derivation of this relation goes through two stages.

Stage 1: Prove that the ratio D_0 / A_e is the same for any antenna.

Consider two antennas: A1 and A2. Let, first, A1 be the transmitting antenna, and A2 be the receiving one. Let the distance between the two antennas be R . The power density generated by A1 at A2 is:

$$W_1 = \frac{D_1 P_1}{4\pi R^2}$$

Here, P_1 is the total power radiated by A1, and D_1 is the directivity of A1. The power received by A2 and delivered to its load is:

$$P_{1 \rightarrow 2} = A_{e_2} \cdot W_1 = \frac{D_1 P_1 A_{e_2}}{4\pi R^2},$$

where A_{e_2} is the effective area of A2.

$$\Rightarrow D_1 A_{e_2} = 4\pi R^2 \frac{P_{1 \rightarrow 2}}{P_1}$$

Now, let A1 be the receiving antenna and A2 be the transmitting one. One can derive the following:

$$D_2 A_{e_1} = 4\pi R^2 \frac{P_{2 \rightarrow 1}}{P_2}$$

If $P_1 = P_2$, then, according to the reciprocity principle in electromagnetics*, $P_{1 \rightarrow 2} = P_{2 \rightarrow 1}$. Therefore,

$$D_1 A_{e_2} = D_2 A_{e_1}$$

$$\Rightarrow \frac{D_1}{A_{e_1}} = \frac{D_2}{A_{e_2}} = \gamma$$

! γ is the same for every antenna.

Stage 2: Find the ratio $\gamma = D_0 / A_e$ for an infinitesimal dipole.

The directivity of a very short dipole (infinitesimal dipole) is $D_0^{id} = 1.5$ (see **Examples of Section 4**, this Lecture).

The effective aperture of an infinitesimal dipole is $A_e^{id} = \frac{3}{8\pi} \lambda^2$ (see the

Example of Section 10, this Lecture).

$$\gamma = \frac{D_0}{A_e} = \frac{1.5}{\frac{3}{8\pi} \lambda^2} \cdot 8\pi$$

$$\gamma = \frac{D_0}{A_e} = \frac{4\pi}{\lambda^2} \quad (4.60)$$

Equation (4.60) assumes that there are no heat losses in the antenna, no polarization mismatch and no impedance mismatch with the transmission lines/load. If those factors are present, then:

$$A_e = (1 - |\Gamma|^2) |\hat{\rho}_w \cdot \hat{\rho}_a|^2 \left(\frac{\lambda^2}{4\pi} \right) e D_0$$

$$A_e = (1 - |\Gamma|^2) |\hat{\rho}_w \cdot \hat{\rho}_a|^2 \left(\frac{\lambda^2}{4\pi} \right) G_0 \quad (4.61)$$

* Reciprocity in antenna theory states that if antenna #1 is a transmitting antenna and antenna #2 is a receiving antenna, then the ratio of transmitted to received power P_{tra} / P_{rec} will not change if antenna #1 becomes the receiving antenna and antenna #2 becomes the transmitting one.